

# **User Manual**

## **DH7 DECT Handset**

## **About this document**

### **Safety Precautions**

IMPORTANT: Read the Safety Precautions in [Appendix B.Safety Precautions](#) before using the handset.

Save this manual. It includes important Safety Precautions and operating instructions. Save all instructions for future reference.

## Contents

<b>1 Introduction</b>	<b>1</b>
1.1 Abbreviations and Glossary	1
1.2 Functions and Accessories	2
<b>2 Descriptions</b>	<b>4</b>
2.1 The DECT Handset	5
2.2 Chargers	6
2.2.1 DC3 Desktop Charger and DP1 Desktop Programmer	6
2.2.2 CR3 Charging Rack	6
2.2.3 Battery Pack Charger	6
2.3 Icons and Text in the Display	7
2.4 Keys and Buttons	11
2.4.1 Off-hook key	11
2.4.2 On-hook and On/Off Key	11
2.4.3 Navigation/Confirmation Key	11
2.4.4 Sound off Key	11
2.4.5 Mute and PTT Button	11
2.4.6 Key Lock and Upper and Lower Case Key	11
2.4.7 Soft Keys	12
2.4.8 Hot Keys	12
2.4.9 Multifunction Button	12
2.4.10 Volume Button	12
2.5 Alphanumeric Keys	13
2.6 Accessories	14
2.6.1 Belt Clips	14
2.6.2 Security Cord	14
2.6.3 Carrying case	14
2.6.4 Headset	14
<b>3 Menu Tree</b>	<b>15</b>
3.1 Calls	15
3.2 Contacts	16
3.3 Profile	16
3.4 Messaging	17
3.5 Services	17
3.6 Shortcuts	18
3.7 Connections	19
3.8 Settings	20
3.9 In Call	21
3.9.1 Additional In Call Functions	21

3.10 Customizing the Menu Tree .....	21
<b>4 Basic Operation .....</b>	<b>22</b>
4.1 Switch the Handset On and Off .....	22
4.2 Log a Shared Phone On and Off .....	22
4.3 Turn the Audible Signal On or Off .....	23
4.4 Lock and Unlock the Keypad .....	23
4.5 Lock and Unlock the Handset .....	24
4.6 Mute Handset on Incoming Call or Message .....	24
<b>5 Calling.....</b>	<b>25</b>
5.1 Open the Call List .....	25
5.2 Incoming Call .....	25
5.2.1 Answer a Call .....	25
5.2.2 Decline a Call .....	25
5.2.3 End a Call .....	25
5.3 Outgoing Call .....	26
5.3.1 Pre-Dial .....	26
5.3.2 Post-Dial with Headset Button .....	26
5.3.3 Dial Using a Pre-programmed Number .....	26
5.3.4 Dial a Number from the Call list .....	26
5.3.5 Dial Last Called Number with Headset Button .....	26
5.3.6 Dial the Sender of a Message .....	27
5.3.7 Dial a Number from Contacts .....	27
5.3.8 Dial a Name from the Central Phonebook .....	27
5.3.9 Dial a Number from the Company Phonebook .....	27
5.4 During a Call .....	28
5.4.1 Adjust the Volume during a Call .....	28
5.4.2 Open Contacts during the Call .....	28
5.4.3 Open Messaging Menu during a Call .....	28
5.4.4 Turn the Microphone On or Off during a Call .....	28
5.4.5 Lock and Unlock the Keypad during a Call .....	29
5.4.6 Audio Transfer .....	29
5.4.7 Start a New Call during Conversation .....	29
5.4.8 Switch between Calls .....	29
5.4.9 End a Call .....	30
5.4.10 Transfer a Call .....	30
5.4.11 Transfer to New Call .....	30
5.4.12 Conference Call .....	31
5.4.13 Call Back .....	31
5.4.14 Send Call Waiting .....	31
5.4.15 Answering Call Waiting .....	32

5.4.16 DTMF .....	32
5.4.17 DECT Info .....	33
5.4.18 Send Data .....	33
5.5 Loudspeaking Function .....	33
5.6 Call Diversion .....	33
5.7 Emergency Calls .....	34
<b>6 Messaging .....</b>	<b>35</b>
6.1 Mini Messaging .....	35
6.2 Message List .....	35
6.3 Receive a Message .....	35
6.3.1 Read a Stored Message .....	36
6.3.2 Reply to a Message .....	36
6.3.3 Delete Messages .....	36
6.3.4 Forward a Message .....	36
6.3.5 Call the Sender of the Message .....	36
6.3.6 Call a Number Included in a Message .....	37
6.3.7 Save Number .....	37
6.3.8 Message Templates .....	37
6.3.9 Write and Send a Message .....	38
6.3.10 Open a Sent Message .....	38
6.3.11 Send to Another Destination .....	39
6.3.12 Review Inbox Content while Reading a Message .....	39
6.4 Receive a Message with Request for Answer .....	39
6.4.1 Accept or Reject the Message .....	39
6.5 Message Queuing and Message Priority .....	39
6.6 Message Priority and Call Priority .....	40
6.7 Interactive Messaging .....	40
6.8 Message Indication Repetition .....	41
6.9 Colored Messaging .....	41
6.10 Decline a Call with a Predefined Message .....	42
6.11 Answering a Text Message with a Predefined Message .....	42
6.12 Calling while Reading a Text Message .....	43
6.12.1 Calling the Message Sender .....	43
6.12.2 Calling a Different Party .....	43
6.13 Mobile Data .....	44
6.13.1 Send Mobile Data .....	44
6.13.2 Send Mobile Data with a Prefix .....	44
6.14 Voicemail .....	44
6.14.1 Receive a Voicemail .....	44
6.14.2 Check the Voicemail inbox .....	44

6.14.3 One Key Voicemail Access .....	45
<b>7 Alarm Operation.....</b>	<b>46</b>
7.1 Push-button Alarm .....	46
7.2 Acoustic Location Signal .....	46
7.3 Test Alarm .....	46
7.4 Alarm with Location Information .....	46
7.4.1 Alarm with Data .....	46
7.5 Automatic Call after Alarm .....	47
<b>8 Menu Operation.....</b>	<b>48</b>
8.1 Connections .....	48
8.1.1 Bluetooth .....	48
8.1.2 Headset .....	49
8.1.3 System .....	50
8.1.4 In Charger Action when in Call .....	51
8.1.5 In Charger Action when not in Call .....	52
8.2 Calls .....	52
8.2.1 Call List .....	53
8.2.2 Missed Calls .....	54
8.2.3 Call Time .....	54
8.2.4 Push to Talk .....	54
8.2.5 Accept an Invitation .....	55
8.2.6 Decline a PTT Invitation .....	57
8.2.7 Call a PTT Group .....	57
8.2.8 Re-join a Group .....	57
8.2.9 Call Services .....	57
8.3 Shortcuts .....	59
8.3.1 Define Soft Keys .....	59
8.3.2 Define Hot Keys .....	60
8.3.3 Define Navigation Key .....	60
8.3.4 Define Multifunction .....	60
8.4 Services .....	60
8.4.1 Add Services .....	61
8.4.2 Edit Services .....	61
8.4.3 Delete Services .....	61
8.5 Messaging .....	61
8.5.1 Inbox .....	62
8.5.2 Write New Messages .....	63
8.5.3 Unsent Messages .....	63
8.5.4 Sent Messages .....	63
8.6 Profiles .....	64

8.7 Contacts .....	65
8.7.1 Call Contact .....	66
8.7.2 Add Contact .....	66
8.7.3 Edit Contact .....	67
8.7.4 Set Ring Signal for a Contact .....	67
8.7.5 Delete Contact .....	67
8.7.6 Central Phonebook .....	67
8.8 Settings .....	68
8.8.1 Sound and Alert Settings .....	68
8.8.2 Keypad Lock Settings .....	69
8.8.3 Phone Lock Settings .....	70
8.8.4 Display Settings .....	71
8.8.5 Time and Date Settings .....	72
8.8.6 Answering .....	73
8.8.7 Change Text size for Messages .....	73
8.8.8 Change the Menu Language .....	73
8.8.9 Change Owner ID .....	74
<b>9 Procedure Call .....</b>	<b>75</b>
<b>10 System Profiles .....</b>	<b>76</b>
10.1 System Profile Status Indications .....	76
<b>11 Advanced Functions .....</b>	<b>77</b>
11.1 Admin Menu .....	77
11.2 Clear Lists in Charger .....	77
<b>12 System Handling.....</b>	<b>78</b>
12.1 Software Upgrade and Additional Features .....	78
12.2 Handset Updates via Charging Rack .....	78
<b>13 Troubleshooting.....</b>	<b>80</b>
<b>14 Operation Notice .....</b>	<b>83</b>
14.1 Accessibility and Voice Quality .....	83
<b>15 Maintenance.....</b>	<b>84</b>
15.1 Maintenance of Batteries .....	84
15.1.1 Battery Warnings .....	84
15.1.2 Charge the Battery .....	84
15.1.3 Charge Spare Batteries .....	84
15.1.4 Replace the Battery .....	84
15.2 Easy Replacement of Handset .....	85
15.2.1 Before Starting Easy Replacement Procedure .....	85
15.2.2 Easy Replacement Procedure .....	85
15.3 Attach the Hinge-type Clip .....	88

---

15.4 Attach the Swivel-type Clip .....	88
15.5 Attach Cover for No Clip .....	88
<b>16. Energy Efficiency.....</b>	<b>90</b>
<b>17 Related Documents.....</b>	<b>91</b>
<b>18 Document History .....</b>	<b>92</b>
<b>Appendix A. Bluetooth Headset.....</b>	<b>93</b>
<b>Appendix B. Safety Precautions.....</b>	<b>99</b>



## 1 Introduction

This document describes features and settings available for the DH7 handset. The handset is a feature-rich handset with color display, telephony, messaging, and Bluetooth. It is designed to be used in medium demanding environment such as hospital environment, but also office environment.

It is suitable for users dependent of being reachable and/or having a need for mobile voice and messaging features, which makes it ideal for applications where the user needs either one way messaging or to be able to interact with other users. The color display enhances and simplifies the use of the handset.

Read the [2 Descriptions](#) on page 4 before using the handset.

For software download and parameter settings, read the Installation and Operation Manual for Portable Device Manager (WinPDM), Windows version, User Manual for Device Manager and the Configuration Manual for the DH7 DECT Handset; see [17 Related Documents](#) on page 91.

### 1.1 Abbreviations and Glossary

Device Manager:	Application for management of handsets, charging racks, etc.
WinPDM:	Portable Device Manager: An application, running on a PC, for managing portable devices, charging racks, etc.

## 1.2 Functions and Accessories

NOTE: Some functions are license/system dependent, or require configuration in handset via WinPDM/Device Manager.

<b>Accessories</b>			
Desktop charger			
Desktop programmer			
Charging rack			
Battery pack charger			
Carrying case			
Belt Clip			
hinge-type			
swivel-type			
Security cord			
Headset with microphone on boom			
Headset with microphone on cable			
Bluetooth headset			
<b>Functions</b>	<b>DH7-T</b>	<b>DH7-M</b>	<b>DH7-P</b>
<b>General</b>			
Easy registration	x	x	x
Enhanced DECT Security	x	x	x
Vibrator	x	x	x
Headset connector	x	x	x
Loudspeaking function	x	x	x
3 Programmable Soft keys	x	x	x
9 Programmable Hot keys	x	x	x
Profiles	x	x	x
System profiles	-	x	x
Shared phone	x	x	x
Contacts (250 contacts)	x	x	x
Central phonebook	x	x	x
Company phonebook (1000 contacts)	x	x	x
Downloadable languages	x	x	x
Multifunction button	x	x	-
Programmable Navigation key	x	x	x
Upgradable to Messenger	x	-	-
Upgradable to Protector	x	x	-
Centralized management	x	x	x
Personalized menus	x	x	x
Easy replaceable battery	x	x	x

<b>Functions</b>	<b>DH7-T</b>	<b>DH7-M</b>	<b>DH7-P</b>
Easy replacement of handset	X	X	X
Handset restrictions	X	X	X
Bluetooth	X	X	X
<b>Telephony</b>			
Push to Talk (PTT)	-	X	X
Procedure call	X	X	X
Voicemail access	X	X	X
Microphone on/off during call	X	X	X
Five predefined emergency numbers	X	X	X
<b>Messaging</b>			
Mini messaging (12 characters)	X	-	-
Data Send	-	X	X
Colored messaging	-	X	X
Interactive messaging	-	X	X
Patient ECG Waveform Monitoring	-	X	X
Data with prefix	-	X	X
<b>Alarm</b>			
Push button alarm	-	-	X
Acoustic Location Signal (ALS)	-	-	X
Alarm with data	-	-	X
<b>Location</b>			
IR Location	-	-	X
Location, base stations	-	X	X
DECT Location	-	X	X

## 2 Descriptions

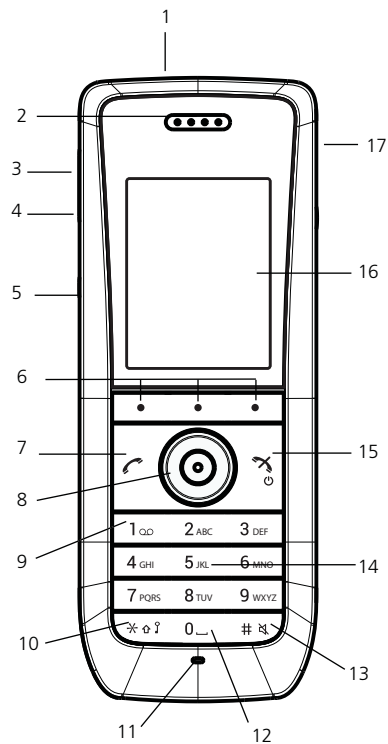

Figure 1. Description of the handset.

- 1 Multifunction/Alarm button  
This button can be used as a shortcut to functions; long or double press modes. Depending on what model of handset that is used, the button can be used as a push button alarm or the button may be configured as a PTT button. For information about what functions that are supported by existing handset models, see [1.2 Functions and Accessories](#) on page 2.
- 2 Earpiece speaker
- 3 Volume button (up)  
To increase the speaker volume
- 4 Volume button (down)  
To decrease the speaker volume
- 5 Mute and PTT button  
To turn on/off audible signals in idle mode, silencing the ring signal at incoming call, and to turn on/off the microphone during a call.
- 6 Soft keys  
The 3 Soft keys can be pre-programmed or used with GUI
- 7 Off-hook key  
To answer a call, to pre-dial a number, and as a shortcut to the Call list.
- 8 Five-way navigation key  
Navigation key with Left, Right, Up, Down, and Confirmation (in the middle). These keys, except the middle key, can also be programmed for shortcuts.

- 9 Voicemail access  
A quick access to the handset's Voicemail. This is a system dependent feature.
- 10 Key lock and Upper/Lower case  
Combined key lock and Upper/Lower Case
- 11 Microphone
- 12 Space  
To add space between text
- 13 Sound off key  
To turn on/off audible signals in idle mode, silencing the ring signal at incoming call, and to turn on/off the microphone during a call.
- 14 Tactile indicators  
There are two tactile indicators to indicate the centre of the key pad
- 15 End and On/Off key  
Combined button; to end a call, to return to standby mode, and to switch the handset on/off by long press.
- 16 Color display  
The full graphic type display is a 1.77 inch TFT. The display has multiple colors and backlighting.
- 17 Headset connector  
The headset connector is for connecting a headset. The connector is protected against dust by using the headset connector cover.

## 2.1 The DECT Handset

**IMPORTANT:** The handset may retain small metal objects around the mouthcap or earcap region.

### Case

The plastic cover parts are made of durable PC/ABS material.

### Antenna

The antenna is integrated inside the handset.

### Loudspeaker

The handset has a separate loudspeaker for the loudspeaking function. It is placed on the back side of the handset.

### Microphone

The microphone is placed on the front bottom side of the handset.

### Clip

There are two different belt clip options to the handset; a hinge-type clip (standard), and a swivel-type clip. See [15.3 Attach the Hinge-type Clip](#) on page 88, or [15.4 Attach the Swivel-type Clip](#) on page 88. Use the clip to attach the handset to a pocket, belt, or similar. The handset can also be without any clip, see [15.5 Attach Cover for No Clip](#) on page 88.

## Battery

The battery is a rechargeable Li-pol battery, placed under a battery cover. See [15.1.4 Replace the Battery](#) on page 84.

The battery is fully charged within four hours. See [15.1.2 Charge the Battery](#) on page 84.

The battery can be charged separately with a special battery charger. See [15.1.3 Charge Spare Batteries](#) on page 84

## 2.2 Chargers

### 2.2.1 DC3 Desktop Charger and DP1 Desktop Programmer

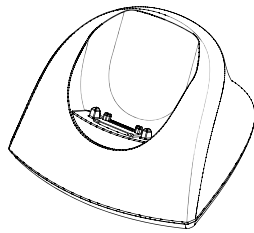

*Figure 2. DC3 Desktop Charger and DP1 Desktop Programmer.*

The DC3 Desktop Charger will only charge the handset, while the DP1 Desktop Programmer will download new software and synchronize parameters. The handset is fully operational while placed in the charger.

The DC3 Desktop Charger is delivered with a plug-in power supply and is connected into an ordinary wall socket.

NOTE: Only use the charger within the temperature range of +5° C – +40° C.

### 2.2.2 CR3 Charging Rack

The CR3 Charging Rack is used for charging several handsets, to synchronize parameters, and for software download.

The built in power supply can charge up to six handsets.

### 2.2.3 Battery Pack Charger

The Battery pack charger is used for charging up to six spare batteries.

## 2.3 Icons and Text in the Display

All functions and settings available to the user are shown as icons and text in the display. The icons and text in the display indicate functions and settings to which you have access. The display normally displays date and time, the Owner ID and handset number. The Owner ID can manually be set by the user.

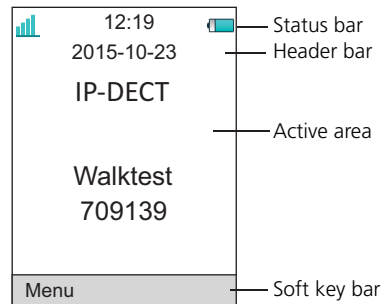

Figure 3. Example of a display configuration in idle mode.

The top row (Status bar) is used for icons which give the user information about signal strength, missed call, new message, phone lock, key lock, sound off, time and battery status. This row is always visible in all screens.

The next row (Header bar) displays the current date, headset connection, Bluetooth connection, and system connection.

The next rows (Active area) are used for information such as the name of the system to which the handset is connected to. A user identity provided from the system and/or an Owner ID can also be displayed if configured in the Settings menu. This is also the area for dialog window text. For example "missed calls" or to confirm an action.

The bottom row (Soft key bar) is used for Soft keys which can be used as shortcuts for functions in the handset. See [2.4.7 Soft Keys](#) on page 12.

The (Scroll bar) is placed to the right of the "Active area". It becomes visible when a menu screen has more than six menus, or if the complete text in a message cannot be displayed on the screen simultaneously.

## Icons



"Signal strength" icon is visible in the upper left corner. The staples shown in display depends on the signal strength.



"Full battery" icon is displayed in upper right corner.



"Low battery warning" icon is shown when the battery has 10% or less remaining capacity left.



"Empty battery warning" icon is flashing when the battery has 5% or less remaining capacity left.



"Sound off" icon is displayed when the Sound off key or Mute button is pressed.



"Microphone off" icon indicates a silenced microphone. It is displayed after a long press on the Sound off key, Mute button during a call.

During a PTT call, the microphone is silenced when the PTT button is released.



"Silent volume" icon is displayed when the volume has been set to "Silent".



"Loudspeaking" icon is displayed in the soft key bar during a call. Pressing this icon turns on the loudspeaker.



"Loudspeaking off" icon is displayed after the soft key for Loudspeaking icon has been pressed. Pressing this icon turns off the loudspeaker.



"New message" icon or "Interactive message" icon indicates that a new text message (or messages) has arrived. The icon remains in the status bar until all new messages in the inbox are read.



"Request for answer" icon in front of a message indicates that this message must be acknowledge or rejected.



"Voicemail message" icon is displayed in the status bar when there are voicemails. The icon remains until voicemail has been listened to.



"Voicemail message" icon is displayed in the message inbox when there are voicemails. The icon remains until voicemail has been listened to.



"Read message" icon or "Read Interactive message" icon in front of a message shows that this message once has been read.



"Sent message" icon





"High prio" or "Alarm prio" icon indicates high priority of a message.





"Key lock" icon indicates a locked keypad.





 "Locked entry" icon indicates that the contact can not be edited or deleted by the user.

 "Phone lock" icon indicates a locked handset.

 "Bluetooth" icon indicates that Bluetooth is enabled.

 "Bluetooth headset" icon indicates that a Bluetooth headset is connected to the handset.

 "Headset" icon indicates that a corded headset is connected to the handset.

 "Outgoing call" icon is added to all outgoing calls in the call list.

 "Incoming call" icon is added to all answered calls in the call list.

 "Push to talk" icon is added to all incoming, outgoing, missed and answered PTT calls in the call list/missed calls.  
Note: The icon is added when a PTT invitation is managed as a call only.

 "Missed call" icon is added to all missed calls in the call list.

 "Missed call" icon indicates missed calls in the status bar.

 "WinPDM/Device Manager communication" icon is visible when handset is communicating with WinPDM/Device Manager via advanced charger.

 "Profile active" icon

### Menu icons

 The "Contacts" menu contains all names/numbers in the Contacts list. In addition, a company phonebook\* with up to 1000 entries can be downloaded to the handset via the WinPDM. A central phonebook\* can also be accessed from the "Contact" menu.

 The "Services" menu contains menu shortcuts used to customize an own menu.

 The "Messaging" menu contains all message handling such as reading and writing messages.



The "Calls" menu contains call lists, call time, and call services\*. Call services is configured in the WinPDM/Device Manager.



The "Connections" menu contains Bluetooth connection, headset selection, System selection, and In charger selection.



The "Settings" menu contains personal handset settings such as changing the ring volume, selecting language, etc.



The "Shortcuts" menu contains shortcuts for the Soft keys, Hot keys, Navigation keys, and the Multifunction button.



The "Profiles" menu allows up to four different profiles to be added. The "Normal" profile is active by default.

\* System dependent.

## 2.4 Keys and Buttons

### 2.4.1 Off-hook key



This key is used for connecting calls. One short press in standby mode opens the call list.

### 2.4.2 On-hook and On/Off Key



This key is used for disconnecting calls and returning to main screen. A long press in standby mode switches the handset on or off.

### 2.4.3 Navigation/Confirmation Key

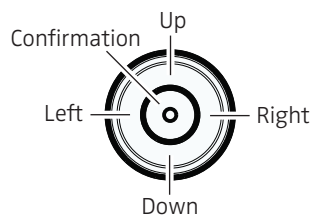

Use this key to step in the menu and when working in text mode. The picture on the left shows how to press the navigation key to step left / right and up / down in the menu.

The navigation key can be programmed, "Up" is by default a shortcut to the Inbox, and "Down" is a shortcut to Call contact. During a call the volume can be increased or decreased by pressing up and down on the navigation key.

### 2.4.4 Sound off Key



A long press on the key in idle mode, changes between ring signal on/off. At incoming call, a short press on the key silences the ring signal. During a call, a long press on the key changes between microphone on/off.

### 2.4.5 Mute and PTT Button



A long press on the Mute button in idle mode, changes between ring signal on/off, at incoming call, a short press on the button silences the ring signal. During a call, a long press on the button changes between microphone on/off.

During a PTT call, the microphone is silenced when the PTT button is released.

### 2.4.6 Key Lock and Upper and Lower Case Key



This key is to lock the keypad in combination with the soft key "Lock". It is also for switching between upper and lower case and digits.

### 2.4.7 Soft Keys

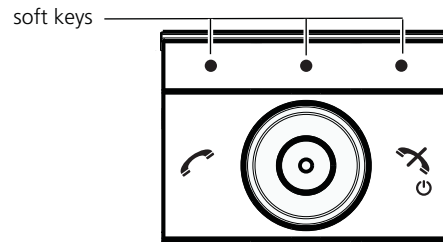

Figure 4. Soft Keys.

The three Soft keys are located just beneath the display and the functions of each Soft key is indicated by text in the display just above the keys.

In idle mode, the Soft keys can be used for specific functions defined by the user of the handset.

### 2.4.8 Hot Keys

Any key "2" - "9" can be set to a Hot Key. A long press on any of these numbers in stand by mode are by default a shortcut to the Call contact list. The list is in alphabetic order, and depending on which key that is pressed is dependent on where in the list the contact appears.

A Hot Key can be programmed to give access to frequently used functions such as dialling a specific handset number, a shortcut on the menu, or sending an SMS.

### 2.4.9 Multifunction Button

NOTE: The support for this feature is dependent on what model of handset that is used. For more information, see [1.2 Functions and Accessories](#) on page 2.

This button can be used as a shortcut to functions; long or double press modes. It is by default not used, but can be defined by the user of the handset. If the button is defined, it can be used in standby mode only.

### 2.4.10 Volume Button

The two buttons placed on the upper left side of the handset are used for increasing/ decreasing the earpiece, headset, and the loudspeaker volume.

## 2.5 Alphanumeric Keys

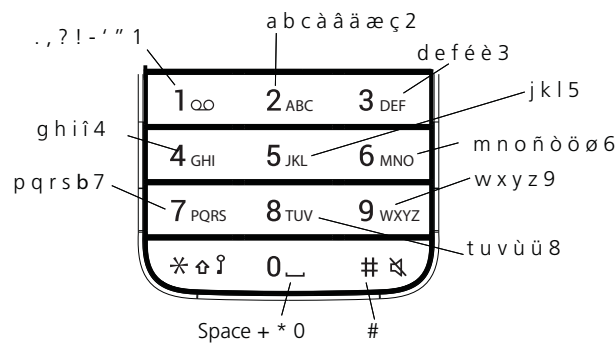

Figure 5. Available characters.

NOTE: Depending on the selected menu language and character setting in the Device Manager, other characters can be available. This means that the character order can differ from the figure above.

### In standby mode, and number input mode

- A short press on a key enter the digits "0" - "9" and the characters \* and #.
- A long press on the "0" key adds a "+" to the number.
- Enter a pause in number input mode by a long press on the #-key. A pause is indicated by a "P" in the display.
- A long press on the \*-key changes the tone sender on. Tone sender on is indicated by a "T" in the display.

### In text input mode

- A short press on a key 0-9, displays the first available character on that specific key. The marked character is selected after a timeout, or when another key is pressed.
- To change to upper or lower case, press the \*-key before entering the character. The \*-key can also be used to display only the digits.
- To add space in the text, make a short press on key 0.
- The first character entered in a message, or when adding or editing a name in the Contacts menu, is an upper level character followed by lower level characters, unless the \*-key is pressed before entering the character. To switch between Abc, ABC, abc, and 123 the \*-key is pressed.
- A long press on the #-key displays special characters.
- A long press on the \*-key opens a menu to change writing language (Default follows the menu language setting).

## 2.6 Accessories

### 2.6.1 Belt Clips

Two belt clip options are available:

- Hinge-type clip  
The clip on the back of the handset is used to fasten the handset to a belt or similar. The clip can also be changed to a swivel-type.
- Swivel-type clip  
The ordinary belt clip can be replaced with a special swivel-type belt clip adapted to firmly place your handset onto your belt.

**Note:** The handset can also be used without any clip on, see [15.5 Attach Cover for No Clip](#) on page 88.

### 2.6.2 Security Cord

The security cord is 800 mm long. The security cord is attached directly to the handset.

### 2.6.3 Carrying case

The carrying case is especially designed for the handset. The carrying case comes with a swivel type belt clip and the handset is fully operational while placed in the carrying case.

### 2.6.4 Headset

A headset is recommended if the handset is frequently used or the user want to have both hands free. The headset comes in three versions; microphone integrated in the cable, microphone on a boom and hearing protection.

In order to achieve optimal audio quality with the different headset types it is recommended to select the corresponding headset profile. See [8.1.2 Headset](#) on page 49 for more information.

### 3 Menu Tree

#### 3.1 Calls

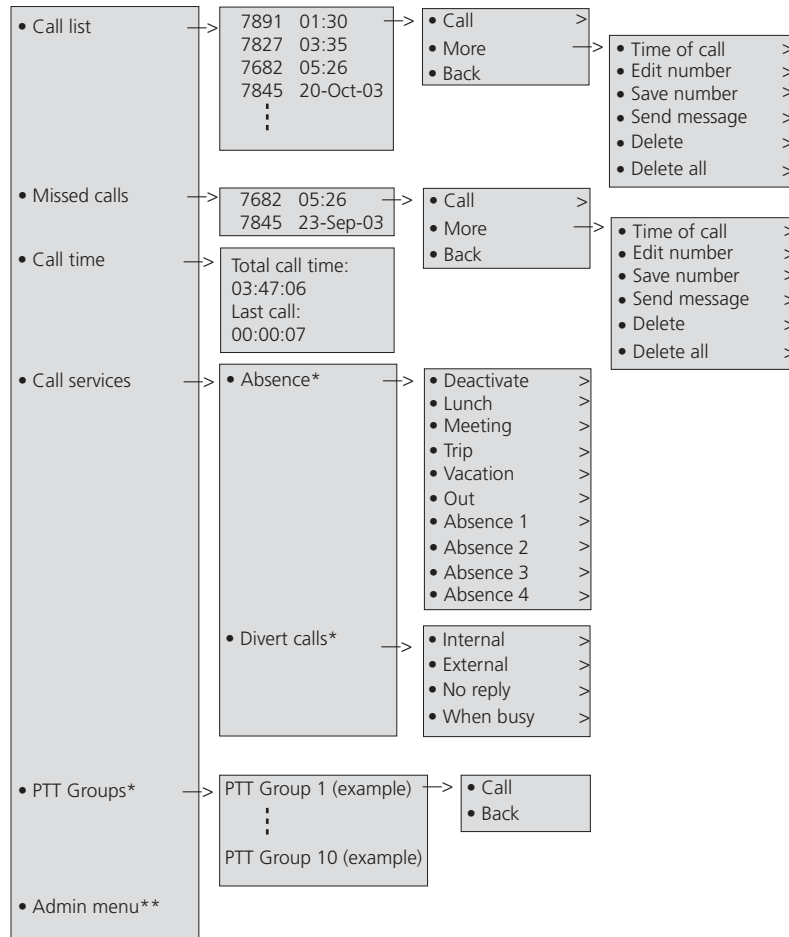

\*) Visible if defined in the WinPDM/Device Manager

\*\*) WinPDM/Device Manager visible if the Admin menu is activated.

### 3.2 Contacts

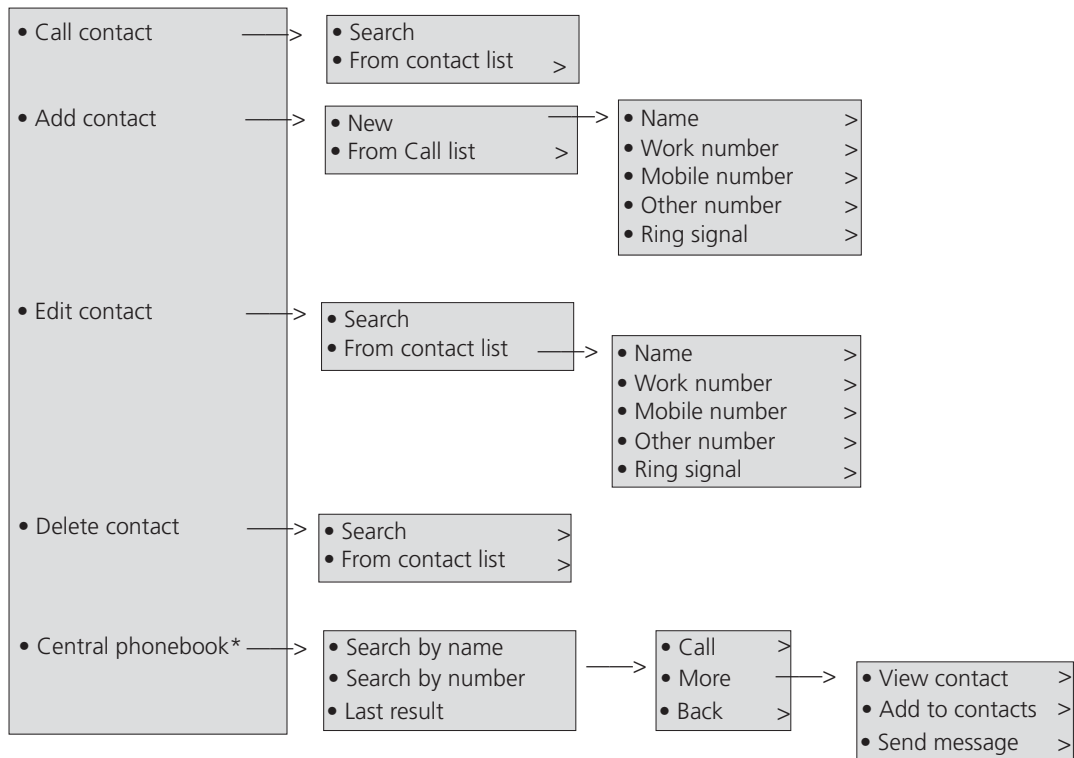

**Tip:** When adding or editing a number in a contact, a variable or the character *U* in the *Work/Mobile/Other* number field can be added that allows the user to enter one or more additional numerical characters before calling the number. See [9 Procedure Call](#) on page 75 for more information.

### 3.3 Profile

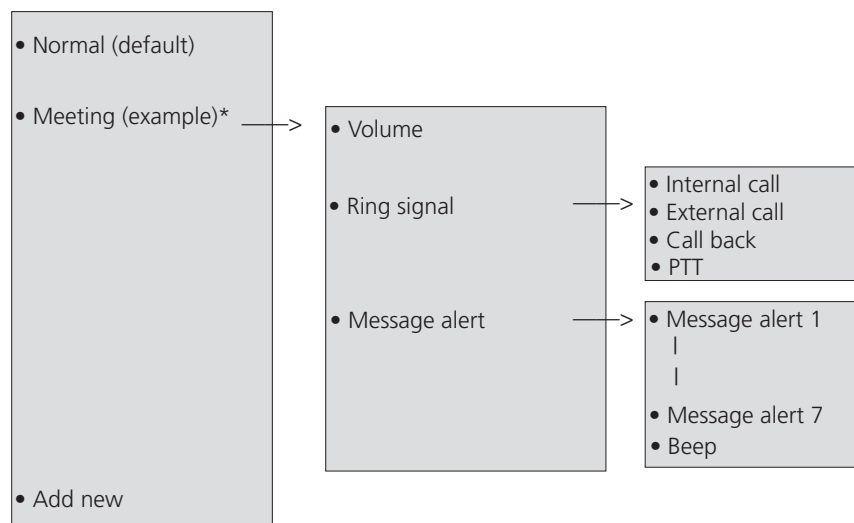

\*) This example profile does not have all applicable settings.



### 3.4 Messaging

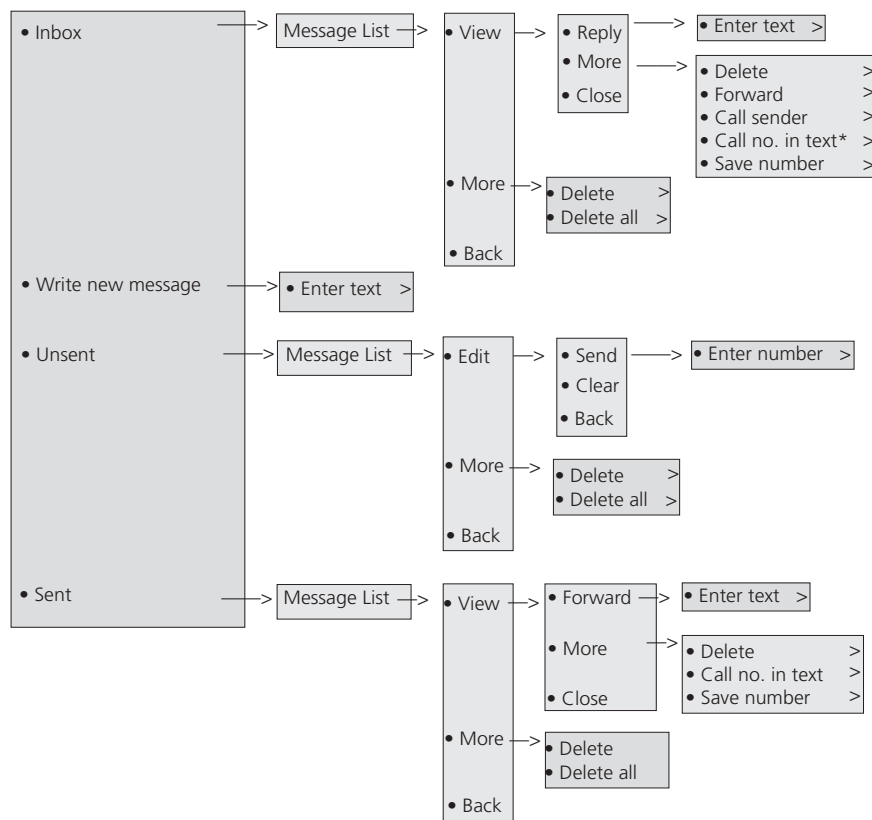

\* Visible if the number consists of minimum 3 digits.

### 3.5 Services

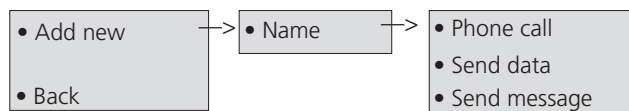

**Tip:** When configuring the *Phone call* function, a variable or the character *U* can be added to the *Enter number* field to allow the user to enter one or more additional numerical characters before calling the number. See [9 Procedure Call](#) on page 75 for more information.

### 3.6 Shortcuts

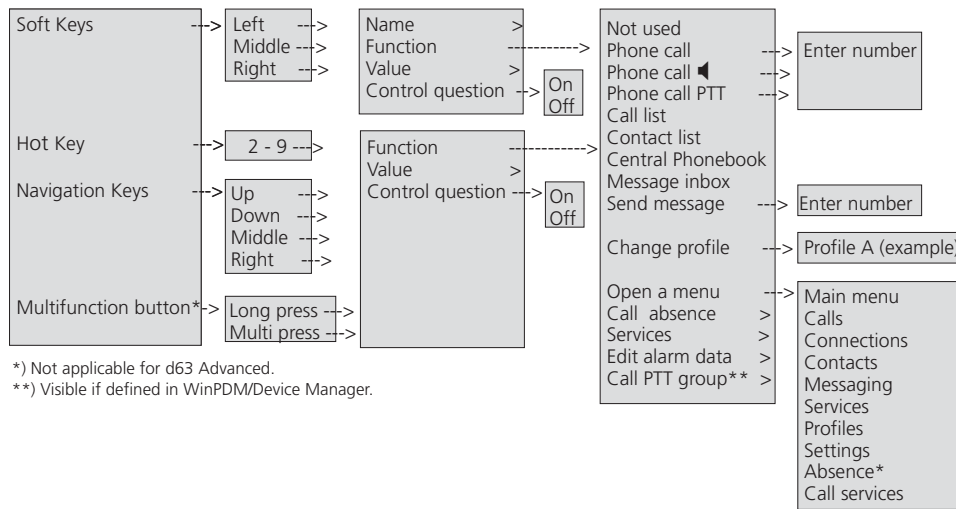

**Tip:** When configuring the *Phone call* function, a variable or character *U* can be added to the *Enter number* field that allows the user to enter additional numerical character(s) before calling the number. See [9 Procedure Call](#) on page 75 for more information.

### 3.7 Connections

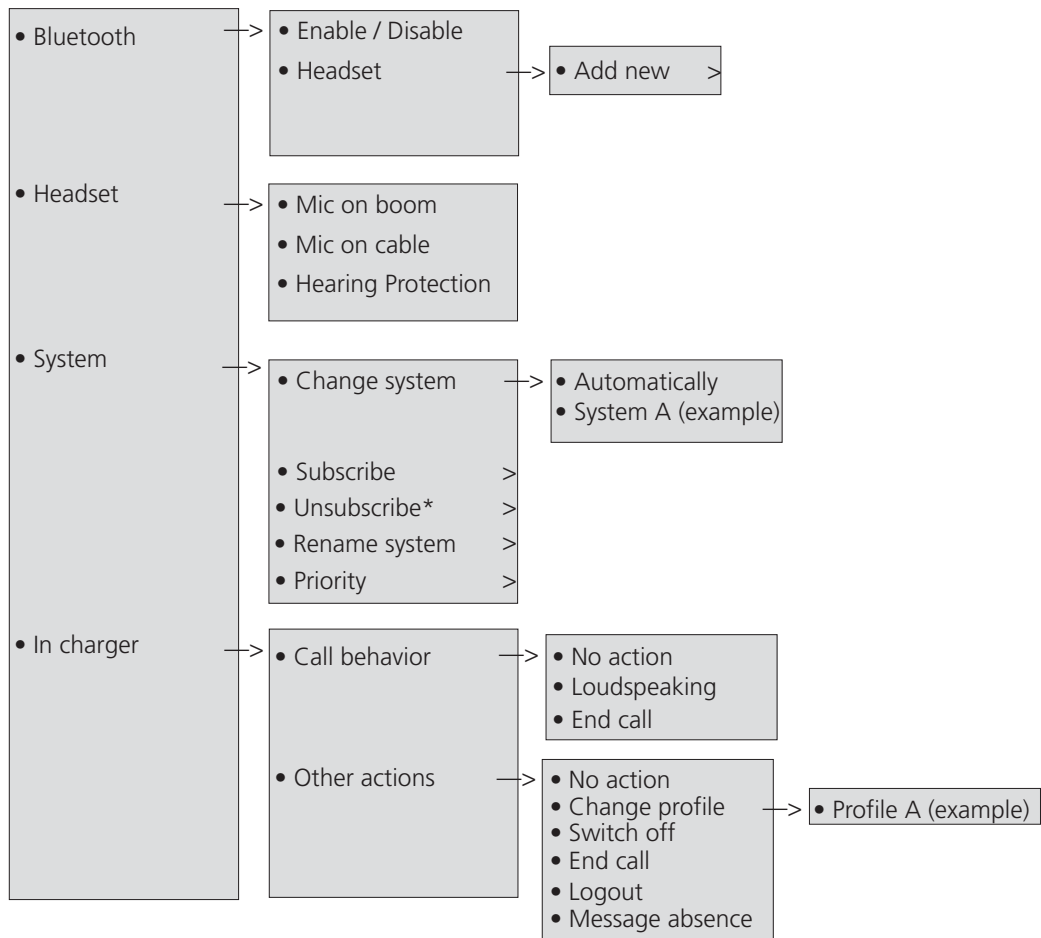

\*) It is not possible to unsubscribe a protected system via the System menu.  
Unsubscription of the system must be made via the Admin menu or the DECT system.

### 3.8 Settings

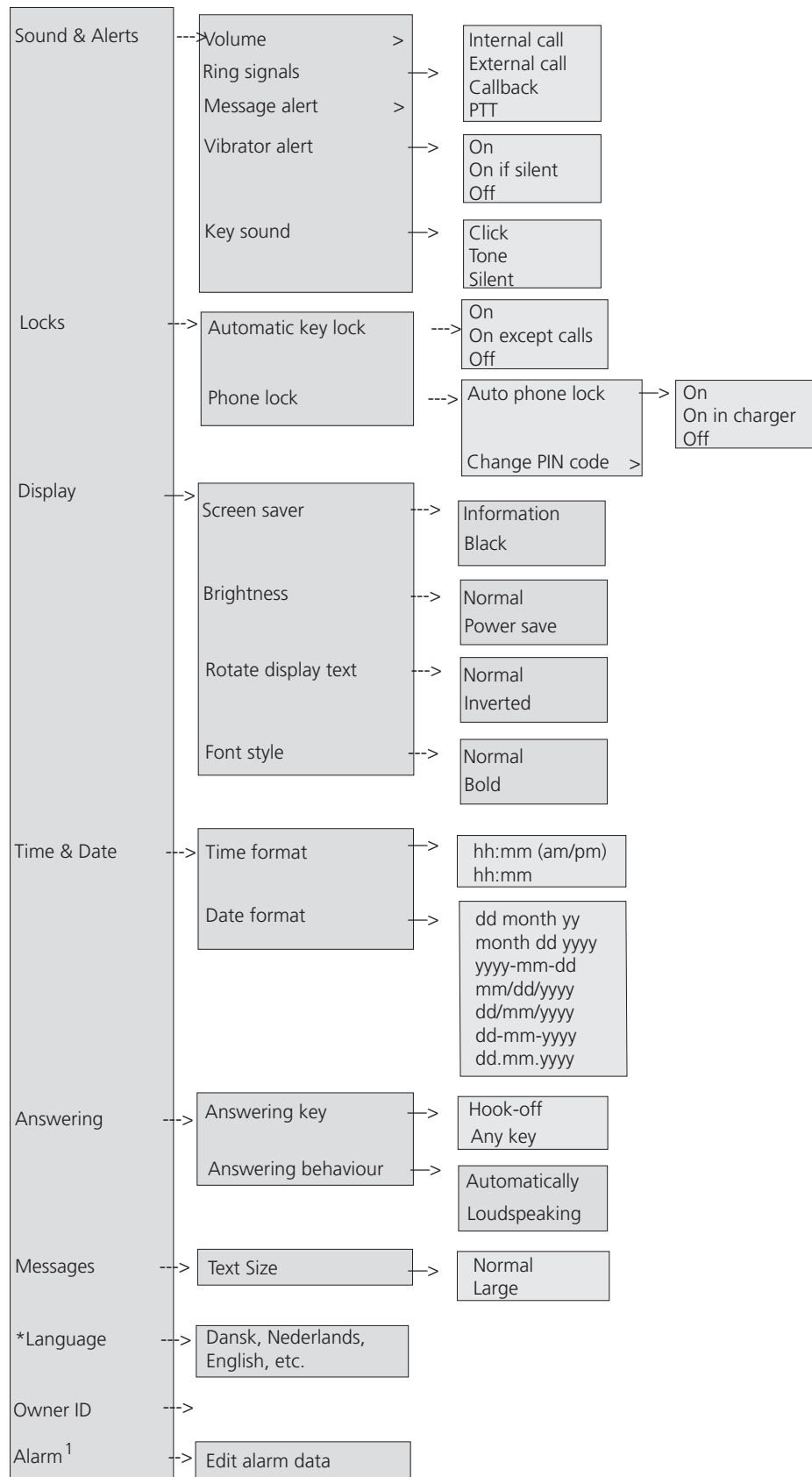

1) The support for this menu is dependent on what model of handset that is used.

### 3.9 In Call

The In Call menu displays a list of functions that can be accessed during a call. To refer to the available functions, press the "More" soft key. Some functions are always provided and others may be made available by the administrator via the WinPDM/Device manager. To use a function, navigate the In Call menu to highlight the required function and then press the "Select" soft key.

The *In call* function can be used in combination with the *Procedure call* function, see [9 Procedure Call](#) on page 75.

**Note:** When calling from a locked handset, there are limitations to what items in the In Call menu are shown. However, the entire menu is accessible when calling from a handset with unlocked keypad.

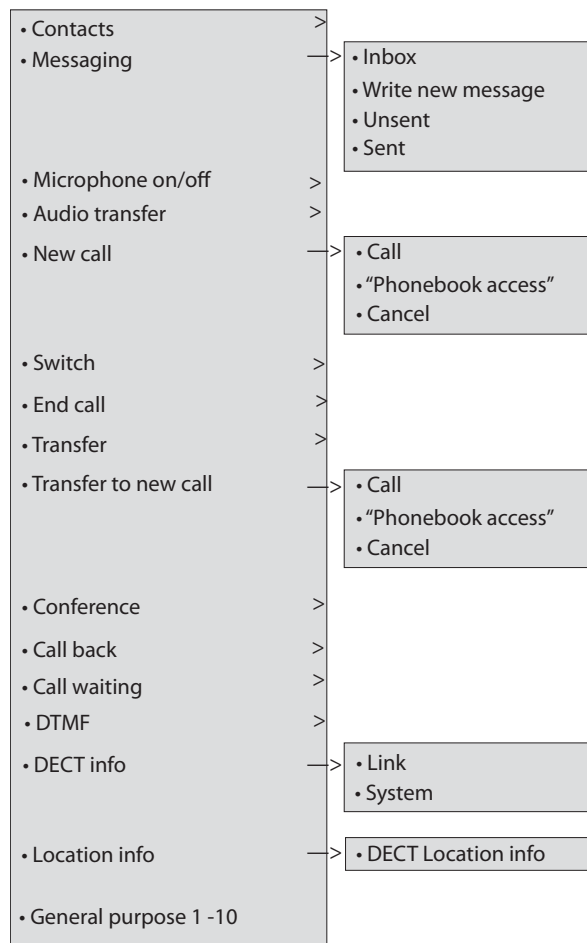

#### 3.9.1 Additional In Call Functions

Besides the default *In Call* functions, up to 10 extra system specific codes or general purposes can be defined. Refer to the Configuration Manual for the handset; see [17 Related Documents](#) on page 91.



### 3.10 Customizing the Menu Tree

The menu tree can be customized by hiding some of the functions that are available but for example not in use. Which functions that should be hidden are defined in the WinPDM. Refer to the Configuration Manual for the handset; see [17 Related Documents](#) on page 91.

## 4 Basic Operation

### 4.1 Switch the Handset On and Off

#### Switch on the Handset

Press and hold . When pressing , the handset vibrates and the display lights up.

#### Switch off the Handset

Prerequisite: The handset is in idle mode:

**Tip:** While in a menu, press  to return to idle mode. If the handset is a shared phone, it must first be logged out to be able to switch off the handset. See [4.2 Log a Shared Phone On and Off](#). A user can be prevented from switching off the handset by enabling the parameter *Prevent switch off* in WinPDM.

- 1 Press and hold .
- 2 A dialog window "Switch off?" is displayed. Confirm by pressing "Yes".

NOTE: If a handset restriction is enabled, it may not be possible to switch off the handset. Refer to the Configuration Manual for the handset; see [17 Related Documents](#) on page 91.

### 4.2 Log a Shared Phone On and Off

NOTE: Shared phone is applicable for IP-DECT systems only. For more information, refer to the Configuration Manual for the handset; see [17 Related Documents](#) on page 91.

The feature shared phone allows more than one user to use a handset. When a handset is configured to be a shared phone, it can be used by any shared phone user in the system. The message and call lists are deleted when a user logs off a handset.

NOTE: If configured in the WinPDM/Device Manager, an emergency call can be made from a handset that is logged off.

#### Log on a Handset

Prerequisite, the handset is switched on. See [4.1 Switch the Handset On and Off](#) for more information.

- 1 A dialog window "Login?" is displayed. Press the soft key "Yes".
- 2 Enter User ID and password.
- 3 Press "Login".

NOTE: The user will be automatically logged out from a previously used handset.



### Log off a Handset

- 1 Press and hold .
- 2 A dialog window "Logout?" appears. Press the soft key "Yes".

NOTE: If a phone is shared and one of the users logs off the shared phone, the lock that prevents the handset from unauthorized use is deactivated. For additional information, see [4.5 Lock and Unlock the Handset](#) on page 24.

## 4.3 Turn the Audible Signal On or Off

**Note:** If handset restrictions are enabled, you might not be able to turn off the audible signal.

A long press on the #  or  in idle mode, changes between ring signal on/off.

The  icon indicates a silenced handset.

## 4.4 Lock and Unlock the Keypad

### Lock and Unlock the Keypad in Idle Mode

To prevent accidentally pressing keys, the keys can be locked.

#### Lock keypad

- 1 Press \* .
- 2 Press "Lock".

Unlock keypad

- 1 Press \* .
- 2 Press "Yes".

**Note:** An incoming call can be answered and the alarm button can be pressed while the keypad is locked. If configured in the WinPDM/Device Manager, an emergency call can also be made while the keypad is locked. Refer to the Configuration Manual for the handset; see [17 Related Documents](#) on page 91.

### Lock/Unlock the Keypad during a Call

To prevent accidentally pressing keys, the keys can be locked during a call. This can be useful when a headset is used and the handset is attached to a pocket or belt.

#### Lock keypad

- 1 Long press \* .
- 2 Press "Lock".

Unlock keypad

- 1 Press \* .
- 2 Press "Yes".

**Note:** When the keypad is locked, the volume buttons and the mute button can be pressed during the call. Depending on what model of handset that is used, the Alarm button can also be pressed. For information about what functions that are supported by existing handset models, see [1.2 Functions and Accessories](#) on page 2.

## 4.5 Lock and Unlock the Handset

The handset can be locked to prevent unauthorized use. If this function is activated, a PIN code has to be entered for example to switch on the handset, to answer an incoming call etc. The default phone lock code (0000) can be changed to any 4 - 8 digit personalized code.

NOTE: If a phone is shared and one of the users logs off the shared phone, the lock that prevents the handset from unauthorized use is deactivated. For additional information, see [4.2 Log a Shared Phone On and Off](#) on page 22.

NOTE: The handset can be configured with predefined emergency numbers that can be called while the handset is locked. Refer to the Configuration Manual for the handset; see [17 Related Documents](#) on page 91. Depending on model of handset, the Alarm button can also be used. For information about what functions that are supported by existing handset models, see [1.2 Functions and Accessories](#) on page 2.

- 1 Enter the "Settings" menu.
- 2 Select "Locks"
- 3 Select "Phone lock".
- 4 Select "Auto phone lock".
- 5 Select "On", "On in charger", or "Off".

## 4.6 Mute Handset on Incoming Call or Message



The handset can be muted temporarily on an incoming call or message. The call is not hung up when the handset is muted. If the call is unanswered, it reverts to voicemail if the handset has been configured for voicemail.

To mute an incoming call or message, press #  or  while the handset sounds.



## 5 Calling

### 5.1 Open the Call List

- 1 Press "Menu",
- 2 Select "Calls"  .
- 3 Select "Call list".
- 4 Select a number.
- 5 Press  or the soft key "Call" to dial. The number can be edited before the call is dialled. Press "More" and select "Edit number". The 25 last received, dialled or missed calls are stored in a call list. See [3.1 Calls](#) on page 15.

### 5.2 Incoming Call

A ring signal or vibrating handset or both, indicates an incoming call. The ring signal and vibrator can be disabled. The calling party handset number or name is displayed. The name is displayed if the calling party handset number is stored in the local phonebook.



To answer the call, press  .

**Tip:** When a headset is connected to the handset, the headset button can be used to answer the call. In addition, the headset button can be configured with a specific function, such as post-dial, dial last called number, or dial a predefined number.

Other answering methods can also be set in the Settings menu, see [3.8 Settings](#) on page 20. The answering methods are; Automatically and Loudspeaking.

When "Automatically" is enabled, all incoming calls are connected automatically.

#### 5.2.1 Answer a Call

When the signal sounds press  or the "Accept" soft key to answer the call. The call can be answered in loudspeaking mode by pressing the  soft key. The name or number of the calling party is displayed if calling line information is available.

#### 5.2.2 Decline a Call

When the signal sounds, press  or the "Decline" soft key to answer the call.

NOTE: If the handset is configured to respond to declined calls with a message template, the "Reply with a message template?" prompt is displayed. For additional information, see [6.10 Decline a Call with a Predefined Message](#) on page 42.

#### 5.2.3 End a Call

Press  to end the call. The duration of the call is shown in the display. The total time of the call can also be retrieved from the Calls menu > Call time.

NOTE: Some systems/PBXs require that the handset sends a DTMF in order to end a call. For more information, refer to the Configuration Manual for the handset; see [17 Related Documents](#) on page 91.

## 5.3 Outgoing Call

### 5.3.1 Pre-Dial

Enter the number and press  to get the line. The number is displayed while dialling. The Soft key "Clear" can be pressed to erase the number if required. The navigation key can be used to step, add or delete digits from the middle of a number.

An international number can be dialled from the handset by entering a + character followed by the country code and local number. To enter the + character, long press the 0 key until the character is shown in the display.

### 5.3.2 Post-Dial with Headset Button

The headset button can be used to obtain a dial tone and dial a number. However, the headset must have been configured via the WinPDM/Device Manager to allow this.



### 5.3.3 Dial Using a Pre-programmed Number

NOTE: The support for Multifunction button is dependent on what model of handset that is used. For more information, see [1.2 Functions and Accessories](#) on page 2.

A Navigation key, Hot key, Soft key or Multifunction button can be programmed with a handset number, as described in section [3.6 Shortcuts](#) on page 18. A headset button can also be programmed with a handset number as long as it has been configured by the administrator via the WinPDM/Device Manager.

To dial a pre-programmed number, press the pre-programmed key or button. The call is connected automatically.

### 5.3.4 Dial a Number from the Call list

- 1 Press .
- 2 Select a number press  or soft key "Call" to dial. The number can be edited before the call is started. Press "More" and select "Edit number".

### 5.3.5 Dial Last Called Number with Headset Button

If a headset is used, the headset button can be used to dial the last called number. However, the headset must have been configured via the WinPDM/Device Manager to allow this.

### 5.3.6 Dial the Sender of a Message

You can call the sender of a message stored in the message list, from the Messaging menu.

- 1 Open the menu by pressing the confirmation button, or the soft key "Menu".
- 2 Select "Messaging".
- 3 Select "Inbox".
- 4 Select message from the list.
- 5 Select "View".
- 6 Select "More".
- 7 Select "Call sender".

### 5.3.7 Dial a Number from Contacts

- 1 Open the menu by pressing the confirmation button, or the soft key "Menu".
- 2 Select "Contacts".
- 3 Select "Call contact".
- 4 Select contact from list, or search name or number by entering characters in the "Search" field.
- 5 Press the Soft key "Call" or the Off-hook key to make the call.

### 5.3.8 Dial a Name from the Central Phonebook

- 1 Open the menu by pressing the confirmation button, or the soft key "Menu".
- 2 Select "Contacts".
- 3 Select "Central phonebook".
- 4 Select "Search by name".
- 5 Enter the first name, last name, or both. Note that the whole name does not have to be entered.

TIP: When searching for a contact, adding and editing a contact, the input language can be changed temporarily by long pressing  $\times \updownarrow$ . This can be used to access characters in a foreign language temporary.

- 6 Press "Search".
- 7 Press the soft key "Call" or Off-hook key to make the call.

### 5.3.9 Dial a Number from the Company Phonebook

- 1 Open the menu by pressing the confirmation button, or the soft key "Menu".
- 2 Select "Contacts".
- 3 Select "Call contact".
- 4 The local and company phonebook appears in the same list but the company names are indicated by a "Locked entry" icon  in front of the name. Select contact from list, or search name or number by entering characters in the "Search" field.
- 5 Press the soft key "Call" or the Off-hook key to make the call.

## 5.4 During a Call

NOTE: Some of these functions are system dependent. The parameters are set up in the WinPDM/Device Manager, refer to the Configuration Manual for the handset; see [17 Related Documents](#) on page 91.

When calling from a locked handset, there are limitations to what items in the In Call menu are visible. However, the entire menu is accessible when calling from a handset with locked keypad.

### 5.4.1 Adjust the Volume during a Call

Press the "Volume up" button to increase the volume, and the "Volume down" button to decrease the volume. The handset stores and keeps the new volume level. The navigation key can also be used to adjust the volume (press up or down on the navigation key).

### 5.4.2 Open Contacts during the Call

- 1 Press the soft key "More" during the call.
- 2 Select "Contacts".
- 3 Press "Select".
- 4 Select "Call contact" for searching a local or company phonebook contact, or select "Central phonebook" for searching a central phonebook contact.
- 5 Press "Select".
- 6 Select or search contact.

NOTE: The selected contact can be called by pressing "Call". When calling the contact, the first call is put on hold. See also [5.4.7 Start a New Call during Conversation](#) on page 29.

### 5.4.3 Open Messaging Menu during a Call

The Messaging menu can be accessed during an ongoing call by pressing the soft key "More".

- 1 Press the soft key "More" during the call.
- 2 Select "Messaging".



See [6 Messaging](#) on page 35 for more information about messaging.

### 5.4.4 Turn the Microphone On or Off during a Call

- 1 Press the soft key "More" during the call.
- 2 Select "Microphone off".
- 3 Press "Select".

The icon  indicates a silenced microphone. This means that the other part in an ongoing call cannot hear you. To turn the microphone back on, do as follows:

- 1 Press the soft key "More" during the call.
- 2 Select "Microphone on".
- 3 Press "Select".

The microphone can be turned off and on by a long press on  or .

When long pressing  or pressing , a short beep is also heard indicating that the microphone is turned on or off. When pressing  in a PTT call, no beep is heard.

### 5.4.5 Lock and Unlock the Keypad during a Call

To prevent accidentally pressing keys, the keys can be locked during a call. This can be useful when a headset is used and the handset is attached to a pocket or belt.

#### Lock keypad

- 1 Long press \*.
- 2 Press "Lock".

#### Unlock keypad

- 1 Press \*.
- 2 Press "Yes".

NOTE: When the keypad is locked, the volume buttons and the mute button can be pressed during the call. Depending on model of handset, the Alarm button can also be pressed. For information about what functions that are supported by existing handset models, see [1.2 Functions and Accessories](#) on page 2.

### 5.4.6 Audio Transfer



To transfer audio between the Bluetooth headset and the handset's earpiece.

NOTE: This option is only visible if a Bluetooth connection is active.

- 1 Press the soft key "More" during the call.
- 2 Select "Audio transfer".
- 3 Press "Select".

### 5.4.7 Start a New Call during Conversation

NOTE: This option is only visible if configured in the handset. For more information, refer to the Configuration Manual for the handset; see [17 Related Documents](#) on page 91.

- 1 Press the soft key "More" during the call.
- 2 Select "New Call".
- 3 Press "Select".
- 4 Enter number, or press  to access the phonebook.
- 5 Press .

### 5.4.8 Switch between Calls

Prerequisite, a new call has been started during conversation, see [5.4.7 Start a New Call during Conversation](#) on page 29.

NOTE: This option is only visible if configured in the handset. For more information, refer to the Configuration Manual for the handset; see [17 Related Documents](#) on page 91.

- 1 Press the soft key "More".
- 2 Select "Switch".
- 3 Press "Select" to switch between the calls.

### 5.4.9 End a Call

Prerequisite, a new call has been started during conversation, see [5.4.7 Start a New Call during Conversation](#) on page 29.

NOTE: This option is only visible if configured in the handset. For more information, refer to the Configuration Manual for the handset; see [17 Related Documents](#) on page 91.

- 1 Press the soft key "More" during the call.
- 2 Select "End Call".
- 3 Press "Select". This ends the current call and the previous call is resumed.

### 5.4.10 Transfer a Call

Prerequisite, a new call has been started during conversation, see [5.4.7 Start a New Call during Conversation](#) on page 29.

NOTE: This option is only visible if configured in the handset. For more information, refer to the Configuration Manual for the handset; see [17 Related Documents](#) on page 91.



When a caller has two ongoing calls, he or she can transfer the first call with the second call.

- 1 Press the soft key "More".
- 2 Select "Transfer".
- 3 Press "Select". This connects the first call with the second call. Your call is automatically disconnected.

### 5.4.11 Transfer to New Call

An ongoing call can be transferred to a new number. When the new call is established, the caller that initiated the transfer is disconnected.

NOTE: This option is only visible when the parameters "New call" and "Transfer" are defined in the handset. For more information, refer to the Configuration Manual for the handset; see [17 Related Documents](#) on page 91.

- 1 Press the soft key "More" during the call.
- 2 Select "Transf. to new".
- 3 Press "Select".
- 4 Enter the number of the person where the ongoing call is to be transferred or press  to access the phonebook.
- 5 Press  to transfer the call. Your call is disconnected automatically.

#### 5.4.12 Conference Call

Prerequisite, a new call has been started during conversation, see [5.4.7 Start a New Call during Conversation](#) on page 29.

NOTE: This option is only visible if configured in the handset. For more information, refer to the Configuration Manual for the handset; see [17 Related Documents](#) on page 91.

By initiate a conference call, an conversation can be made between several participants simultaneously.

- 1 Press the soft key "More".
- 2 Select "Conference".
- 3 Press "Select".



The person initiating the conference call is the conference leader, and the other are participant members of the conference call.

#### 5.4.13 Call Back

When a call is made to a busy handset, an automatically call back can be made when the busy handset is free.

NOTE: This option is only visible if configured in the handset.

When a busy tone sounds, do as follows:

- 1 Press the soft key "More" during the call.
- 2 Select "Call back".
- 3 Press "Select".
- 4 Press  and wait until the handset alerts.
- 5 When the handset alerts, press . The call is started automatically.

#### 5.4.14 Send Call Waiting

This function is used when a calling party receives a busy signal from a party engaged in a call and wishes to notify the party that another call is waiting. To notify the engaged party:

- 1 Press the soft key "More".
- 2 Select "Call waiting".
- 3 Press "Select". The engaged party receives a "Call waiting" signal.

When the line is free it automatically calls the number again. This is system dependent.

Note: The "Call waiting" function is only visible if an administrator has activated it in the handset. For more information, refer to the Configuration Manual for the handset; see [17 Related Documents](#) on page 91.

### 5.4.15 Answering Call Waiting

Depending on system setup and configuration, this feature might be handled in one of two different ways:

#### Method 1

During an ongoing conversation and a short tone for another incoming call appears, do as follows:

- 1 Press the soft key "More" during the call.
- 2 Select "Answer Call waiting".
- 3 Press "Select". The new call is now connected, and the first call is on hold.

When the line is free, the call on hold is automatically dialed again. This is a system dependent feature.

#### Method 2

If a second caller calls during a phone call, the handset beeps and display the text "Internal call" for internal callers and "External call" for external callers. The handset also displays the name or phone number of the second caller. To answer the second caller:

- 1 Press the soft key "Accept".

The text "Switch" briefly appears on screen, and the handset transfers to the second call. The first call is put on hold.

- 2 When finished speaking with the first caller, select the "More" soft key.
- 3 Select "End Call".

The second call is closed and the first call is retrieved.



NOTE: A second call can be rejected by pressing the "Decline" soft key. The second caller hears an engaged tone. The call is logged as a missed call in the handset.

### 5.4.16 DTMF

NOTE: This option is only visible if configured in the handset. For more information, refer to the Configuration Manual for the handset; see [17 Related Documents](#) on page 91.

Some systems and PBXs require that the handset sends Dual Tone Multi Frequency (DTMF) when pressing the keys. DTMF can be enabled as follows:

- 1 Press the soft key "More" during the call.
- 2 Select "DTMF".
- 3 Press "Select". This enables DTMF signals to be used.

TIP: The handset can also be configured to send DTMF when pressing  and pressing releasing . refer to the Configuration Manual for the handset; see [17 Related Documents](#) on page 91.



#### 5.4.17 DECT Info



DECT info is an advanced function intended for an administrator using the handset to measure RF link and system parameters as part of a troubleshooting or site surveying procedure. This option is only visible if the Admin menu is activated as described in section [11.1 Admin Menu](#) on page 77. For more information, refer to the Configuration Manual for the handset; see [17 Related Documents](#) on page 91.

#### 5.4.18 Send Data

User entered data can be sent from the handset by pressing a pre-programmed hot key or soft key, or selecting a Service. Sent data can be used to initiate actions such as opening a door or starting and stopping a machine. The data can either be predefined, entered after the hot key or soft key is pressed, or send when the relevant service is selected.

### 5.5 Loudspeaking Function

There are five options to activate the loudspeaking function:

- Press a Multifunction button, Navigation key, Hot key or Soft key defined as shortcut to a "Phone call " function. When pressing the key/button, a predefined number is called, see [8.3 Shortcuts](#) on page 59.  
NOTE: The support for Multifunction button is dependent on what model of handset that is used. For more information, see [1.2 Functions and Accessories](#) on page 2.
- When receiving a call, press the soft key . The Soft key might have another/no function depending on its configuration of the In call function in WinPDM/Device Manager.
- During a call, press the soft key . The Soft key might have another/no function depending on its configuration of the In call function in WinPDM/Device Manager.
- During a call, put the handset in a charger. Requires that *Loudspeaking* is chosen in the *In Charger* menu.
- This function can also be activated by selecting another answering method, that is, "Automatically" and/or "Loudspeaking". See [8.8.6 Answering](#) on page 73.

### 5.6 Call Diversion

All calls; internal calls, external calls, calls when busy, or calls at no answer can be diverted to another handset number. The diversion is made via the Calls menu > Call services > Divert calls. See [Divert Calls](#) on page 58.

In addition, an absence reason (for example "Lunch", "Meeting", "Trip" etc.) can also be set. The absence reason is set via the Calls menu > Call services > Absence. See [8.2.9 Call Services](#) on page 57.

NOTE: PBX settings for the call diversion must be set in order to show the *Divert calls* menu in the handset. Refer to the Configuration Manual for the handset; see [17 Related Documents](#) on page 91.

NOTE: If both diversion and absence reason are set, the absence reason is used.

Either can a Multifunction button, Soft key or Hot key be preprogrammed with a shortcut to the diversion function or the absence reason/menu. See [8.3 Shortcuts](#) on page 59.

NOTE: The support for Multifunction button is dependent on what model of handset that is used. For more information, see [1.2 Functions and Accessories](#) on page 2.

## 5.7 Emergency Calls

If configured in the WinPDM/Device Manager, any one of up to five predefined emergency numbers can be called, even if the handset or keypad has been locked. For additional information, see sections [8.8.2 Keypad Lock Settings](#) on page 69 and [8.8.3 Phone Lock Settings](#) on page 70.

## 6 Messaging

### 6.1 Mini Messaging

NOTE: The support for this feature is dependent on what model of handset that is used. For more information, see [1.2 Functions and Accessories](#) on page 2.

Depending of what model of handset that is used, it can receive text messages with a maximum of 12 characters. When a text message is received, the message alert signal sounds. The message is displayed in a popup window.

If the received message contains more than 12 characters, the remaining characters are discarded. Only the last received message is displayed. For example, a first message is received and displayed in the popup window. Another message is received and is displayed instead of the prior message which is discarded.

Press "Close" when the message has been read. It is not possible to reply to a message or create and send a new message. The messages are not stored in the handset.

### 6.2 Message List

The thirty last received messages are stored in a list. The message list is located in the Messaging menu "Inbox". Time and date information is included in the message.

If a message is received when the inbox already contains thirty messages, the message in the inbox with the oldest time and date is automatically replaced by the newly received message.

### 6.3 Receive a Message

When a text message is received, the message alert signal sounds. The "New message" icon, and the content of the received message are automatically displayed. The icon remains in the display until all new messages are opened. If the message is received during a call a beep notifies the user.

NOTE: If the phone is locked with a PIN, the user must unlock the phone to access a received message.

Using the handset soft keys and menu selections, a received message can be replied to or forwarded to another party. The sender of the message can be called and a call number can be included in the message text.

While reading a received message, the user can return to the Inbox, review the current inbox content and then return to the message being read.

A received message can be read later by selecting "Close". A received message is stored in the Inbox.

### 6.3.1 Read a Stored Message

- 1 Enter "Messaging" in the menu, see [3.4 Messaging](#) on page 17.
- 2 Select "Inbox".
- 3 Select stored message from the list.
- 4 Press "View" to read the message.

### 6.3.2 Reply to a Message

To reply when receiving a message, do as follows:

- 1 Press "Reply".
- 2 Enter message.
- 3 Press "Send".
- 4 If needed, edit the number to the receiver.
- 5 Press "Send".

### 6.3.3 Delete Messages

- 1 Enter "Messaging" in the menu, see [3.4 Messaging](#) on page 17.
- 2 Select "Inbox".
- 3 Select message to delete.
- 4 Press "More".
- 5 Select "Delete"
- 6 Press "Yes" for confirmation. The message is deleted. To delete all messages in the list, select "Delete all" and press "Yes" for confirmation.

### 6.3.4 Forward a Message

- 1 Enter "Messaging" in the menu, see [3.4 Messaging](#) on page 17.
- 2 Select "Inbox"
- 3 Select message
- 4 Press "View".
- 5 Press "More".
- 6 Select "Forward"
- 7 If needed, write additional text, see [6.3.9 Write and Send a Message](#).
- 8 Press "Send".
- 9 Enter the number to the receiver, or press the middle soft key to open the phonebook.
- 10 Press "Send" to forward the message.



### 6.3.5 Call the Sender of the Message

- 1 Enter "Messaging" in the menu, see [3.4 Messaging](#) on page 17.
- 2 Select "Inbox".
- 3 Select message.
- 4 Press "More".

- 5 Select "Call sender".

### 6.3.6 Call a Number Included in a Message

If the sender has written a number in the message, the number can be called without dialling. This option is only visible if the number consists of minimum 3 digits.

- 1 Select "View".
- 2 Do one of the following:
  - Press "More" and select "Call no. in text".
  - Press .
- 3 If the message contains several numbers, select the number to be called from the list.
- 4 Press "Call", or .

### 6.3.7 Save Number

- 1 Enter "Messaging" in the menu, see [3.4 Messaging](#) on page 17.
- 2 Select "Inbox".
- 3 Select message .
- 4 Select "View".
- 5 Press "More".
- 6 Select "Save number".
- 7 Select "Work number", "Mobile number", or "Other number".
- 8 Add name and press "OK".
- 9 Press "Save". The number is saved in the contact list.

### 6.3.8 Message Templates

Predefined messages contained in message templates can be used in a number of different situations to quickly construct a message rather than having to construct the message completely from scratch.

Up to five predefined messages can be configured for the handset in the WinPDM/Device Manager. This lets the user select and send a message appropriate to the current situation, such as "I am in a meeting" or "I am in the operating theatre".

How to use the WinPDM/Device Manager to create store predefined messages the handset is described in the Message Templates section of the Configuration Manual for the handset; see [17 Related Documents](#) on page 91).

Before a message is sent, the user may edit, add, or remove text from the message. For example, the message "I am in a meeting" could be appended with " - please call back after 1500".

The message template function can be used in the following contexts:

- When a call is received that the user wishes to decline, but still acknowledge with a message, without having to type a completely new message. See [6.10 Decline a Call with a Predefined Message](#) on page 42.
- When a text message is received that the user wishes to answer with a text message without having to type a completely new message. See [6.11 Answering a Text Message with a Predefined Message](#) on page 42.

- When the user is writing a message using the handset Messaging function without having to type a completely new message. See [6.3.9 Write and Send a Message](#) on page 38.

### The Templates Menu

To access a template and use it in one of the ways described above, perform the following steps:

- 1 Open the "Templates" menu as described in the context in which the template is being used.
- 2 Select the required message from the "Templates" menu.
- 3 To edit the message, use the handset navigation key to move to different parts of the message, the handset key pad to add additional text, and the "Clear" soft key to delete unwanted text

### 6.3.9 Write and Send a Message

A message can be constructed from scratch, or from a predefined template that can be used as it is or edited. The maximum message length is normally 160 characters but may be less depending on the character set used.

The first character entered is always upper-case, followed by lower-case character. However, this may be overridden by pressing the \* -key before entering the character.

When pressing a key, the first available character for that key is displayed, see [2.5 Alphanumeric Keys](#) on page 13. To enter the other characters supported by the key, press the key until that character appears in the display.

The keys 0-9, \* or # can be used. Keys 0 and 1 contains special characters, see [2.5 Alphanumeric Keys](#) on page 13 to see all characters.

For example, to enter the character E, press key 3 twice. "E" appears in the display and is selected after a timeout or when another key is pressed.

TIP: If the system supports UTF-8 character encoding, the input language can be changed temporarily by long pressing  $\times \uparrow \uparrow$ . This can be used to temporarily access characters in a foreign language.

To delete a character, press "Clear".

To construct and send a message, perform the following steps:

- 1 Enter "Messaging" menu, see [3.4 Messaging](#) on page 17.
- 2 Select "Write new message".
- 3 Write the message from scratch or select a message template by pressing the "More" soft key and, if required, edit the message as described in [The Templates Menu](#) on page 38.  
NOTE: The "More" key is not displayed if no message templates have been defined.
- 4 When the message is complete, press "Send".
- 5 Enter the call number.
- 6 Press "Send" to send the message.

### 6.3.10 Open a Sent Message

- 1 Enter "Messaging" menu, see [3.4 Messaging](#) on page 17.
- 2 Select "Sent".

- 3 Select message.
- 4 Press "View" to read the message.

#### 6.3.11 Send to Another Destination

- 1 Enter "Messaging" menu, see [3.4 Messaging](#) on page 17.
- 2 Select "Inbox" or "Sent".
- 3 Select message.
- 4 Press "More".
- 5 Select "Forward".
- 6 Press "Send".
- 7 Enter the number.
- 8 Press "Send".

#### 6.3.12 Review Inbox Content while Reading a Message

To review the content of the inbox while reading a received message, perform the following steps:

- 1 Press the "More" soft key
- 2 From the pop-up menu, select "Inbox". The message summaries contained in the inbox are displayed.
- 3 To return to the message previously being read, press the "Back" soft key.

### 6.4 Receive a Message with Request for Answer

In the status bar, a message with request for answer is indicated the same way as an ordinary message, see [6.3 Receive a Message](#) on page 35.

In the message list, the message with request for answer is indicated by the  icon.

#### 6.4.1 Accept or Reject the Message

Press the soft key "Accept" or "Reject".

When an acknowledged message has been replied to, the icon  is shown in the message list. The text "Accepted" or "Rejected", and time and date is also added in the acknowledged message.

NOTE: The option "Delete" is not available for a message with request for answer. An unacknowledged message can only be deleted from the message list.

### 6.5 Message Queuing and Message Priority

To notify about new incoming messages, all incoming messages are placed in a message queue. The sorting order for the message queue depends on the system settings. By default the messages are sorted according to message priority, and thereafter according to arrival time.

The messages in the message queue are automatically displayed for 20 seconds until all messages have been displayed. You can extend the time to display a message by pressing any button. You can also close a message to immediately refer to the next message in the message queue.

The messages that are not closed are put last in the message queue and remain in the message queue until they are closed. They are shown as unread in the message list and are not shown as read until they have been closed.

See Configuration Manual, DH7 DECT Handset, TD 93190EN for more information how to set the parameters.

## 6.6 Message Priority and Call Priority

NOTE: This feature requires settings in the WinPDM/Device Manager, refer to the Configuration Manual for the handset; see [17 Related Documents](#) on page 91.

On incoming calls, the call information dialog is always visible in front of a message by default. The default can be overridden so that messages with a certain priority can be displayed without being interrupted by the call. By setting a call priority, the handset compares the call priority with the message priority to determine which information is to be displayed, that is, the call information dialogue or the message. If the message priority and the call priority are equal, the message is displayed.

## 6.7 Interactive Messaging

NOTE: The support for this feature is dependent on what model of handset that is used. For more information, see [1.2 Functions and Accessories](#) on page 2.

Interactive Messaging (IM) is a function that extends basic messaging. It lets a handset user interact with a server application in the system.

An example can be machinery or equipment that can be accessed from the handset or a personnel calling application. A list of actions can be included in the message sent from the application to the handset.

An IM is indicated and viewed the same way as an ordinary message, see [6.3 Receive a Message](#) on page 35. It is saved along with other messages in the message list.

NOTE: The indication of an IM can differ from an ordinary message depending on the settings in the IM. The application that sends the IM can determine the alert signal volume.

When an IM has been read, the IM may display several options. Mark the one required and press "Select". If the selected option requests input, enter the information needed and press "Ok". A press on the \*-key changes to digit or text input mode depending on whether it is digit or text format in the message. A read message is indicated the same way as an ordinary message.

NOTE: If a handset receives an IM update when the original message already has been deleted, the handset automatically sends a negative acknowledge (NAK) to the system, if requested.

A very simple interactive message can look like the one in [figure 6](#) on page 41. The options depends on the configuration in the client application.



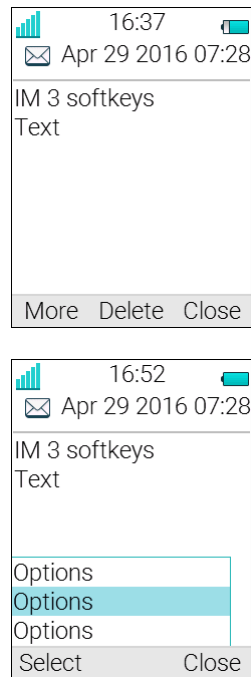

Figure 6. Example of an interactive message

Mobile data from the handset can initiate the application to send the interactive message, see [6.13 Mobile Data](#) on page 44.

## 6.8 Message Indication Repetition

The handset can be configured to repeat the audio and visual message received alert described in [6.3 Receive a Message](#) on page 35. The alert repeats every seven seconds until the user reads the message or turns the alert off. For the appropriate message settings, refer to the Configuration Manual for the handset; see [17 Related Documents](#) on page 91.

Certain system-defined properties can be assigned to a message to give it a high priority, for example, an alarm priority message. Alert repeats start automatically when a high priority message is received. Such messages do not need to be explicitly configured to trigger alert repeats. A high priority alert is repeated every 10 seconds for a maximum of 5 minutes and then the alert stops.

Alerts continue to be repeated until the user presses the hook-on, mute button or soft key for accessing the message.

Note that message indication repeat is a system dependent feature that cannot be activated from the handset.

## 6.9 Colored Messaging

NOTE: The support for this system dependent feature is dependent on what model of handset that is used. For more information, see [1.2 Functions and Accessories](#) on page 2.

Colored messages can be sent to handsets. The sender of a message, that is, an application, determines the color of the message. Colored messaging can be useful for categorizing messages. In [figure 7](#) on page 42, there are two colored messages, a new message and a read message, in the message inbox (left in the figure). The messages are indicated by a

gradient color bar behind the envelopes. In addition, a gradient color bar is shown below the envelop when reading a colored message (right in the figure).

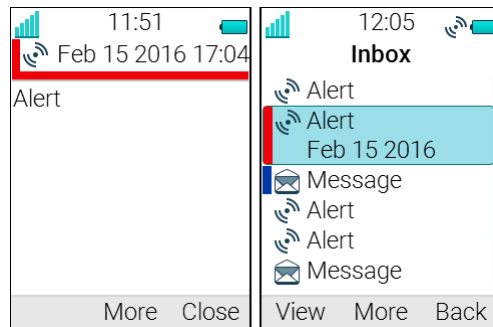

Figure 7. Shows an example of a colored message.

To enable colored messaging, refer to the corresponding manual for the application used. In addition, colored labels can be mapped to message beep codes. refer to the Installation and Operation Manual for Device Manager.

## 6.10 Decline a Call with a Predefined Message

A call may be declined with a predefined message by the called party provided that both parties are connected via a DECT system. To decline a call with a predefined message when the handset rings, perform the following steps:

- 1 In response to the "Reply with a message template?" prompt, press the "Yes" soft key to send a message to the caller. A list of predefined messages is displayed in the "Templates" menu.
- 2 Select, and if required, edit the message as described in [The Templates Menu](#) on page 38.
- 3 Click the soft key "Send". The calling party number is displayed in the handset display.
- 4 Click the soft key "Send". A "Message sent" confirmation is displayed and the message is sent to the caller.

## 6.11 Answering a Text Message with a Predefined Message

To respond to an incoming text message with a predefined message, perform the following steps:

- 1 Press the soft key "Reply"
- 2 Press the "More" soft key. The "Templates" option is displayed.
- 3 Press the soft key "Select". A list of predefined message templates is displayed.
- 4 Navigate to the required message template and press the "Select" soft key. If required, edit the message as described in [The Templates Menu](#) on page 38.
- 5 Press the soft key "Send". The message sender's number is displayed in the handset display.
- 6 Press the soft key "Send". A "Message sent" confirmation is displayed and the message is sent to the caller.

## 6.12 Calling while Reading a Text Message

A user can make a call while reading a text message to review and discuss the message with the called party. The called party can be either:

- The message sender, that is, the same party that sent the text message
- A different party.

The user can activate the loudspeaker function during the call to make it easier to read the received text message while talking to the called party.

### 6.12.1 Calling the Message Sender

To call the message sender while reading and reviewing a received text message, perform the following steps:

- 1 Receive the text message and call the message sender as described in [Call Sender](#) on page 62.
- 2 Wait for the called party to reply. The message is replaced by the ongoing call details. The user may now:
  - Continue with the call without referring back to the received message.
  - Redisplay the message and continue the call to further review and discuss the message. See [Redisplay the Message and Continue with the Call](#) on page 43.
  - Redisplay the message and terminate the call. See [Redisplay the Message and Terminate the Call](#) on page 44.

### 6.12.2 Calling a Different Party

To call another party to read and review a received text message, perform the following steps:

- 1 Open the message as described in [8.5 Messaging](#) on page 61 and press the "More" soft key.
- 2 From the pop-up menu, navigate to the "Call" menu item and press the "Select" soft key. The pre-dial screen is displayed. Enter the number of the party to be called or select a number from the handset call list or local or central phone books.
- 3 Press the "Call" soft key and wait for the called party to reply. The message is replaced by the ongoing call detail. The user may now:
  - Continue with the call without referring back to the received message.
  - Redisplay the message and continue the call to further review and discuss the message. See [Redisplay the Message and Continue with the Call](#) on page 43.
  - Redisplay the message and terminate the call. See [Redisplay the Message and Terminate the Call](#) on page 44.

#### Redisplay the Message and Continue with the Call

- 1 To redisplay the message while the call is ongoing, select the "More" soft key.
- 2 From the pop-up menu, select "Messaging".
- 3 From the Messaging menu, select "Inbox". The received message summary is displayed.
- 4 Press the "View" soft key to display the message in full. If required, use the four-way navigation key to scroll up and down a long text message to reveal the content while reviewing and discussing the message with the called party.

### Redisplay the Message and Terminate the Call

- 1 Press . The call is terminated and the ongoing call summary details are replaced by the redisplayed text message.

## 6.13 Mobile Data

NOTE: The support for this system dependent feature is dependent on what model of handset that is used. For more information, see [1.2 Functions and Accessories](#) on page 2.

### 6.13.1 Send Mobile Data

User entered data can be sent from the handset by pressing a pre-programmed Hot key or Soft key, or selecting a Service. Mobile data can be used for opening a door, starting/stopping a machine etc. The data can either be predefined, or entered after the Hot key/Soft key is pressed or Service is selected.

The data can be predefined when programming the Soft/Hot key or Service, see [8.3.1 Define Soft Keys](#) on page 59, [8.3.2 Define Hot Keys](#) on page 60, or [8.4.1 Add Services](#) on page 61.

### 6.13.2 Send Mobile Data with a Prefix

Mobile data with a prefix is sent from the handset by entering data and then pressing a pre-programmed Hot key or Soft key or select a Service. Mobile data with prefix can be used to send information to an application in the system.

The prefix is predefined by the user when programming the Hot/Soft key or Service, [8.3.1 Define Soft Keys](#) on page 59 on page 46 or [8.3.2 Define Hot Keys](#) on page 60.

## 6.14 Voicemail

NOTE: This feature is only available if configured in the system.

### 6.14.1 Receive a Voicemail

When receiving a voicemail, the content of the voicemail notification is displayed automatically on the screen, and is also indicated by the "Voicemail message" icon  in the status bar.

If the content of the notification is displayed, press "Call" to dial the voicemail. If "Close" is selected, the voicemail can be dialed by a long press on digit key "1" in standby mode, or from the Inbox menu.

Information is stored in the "Messaging" inbox (see [3.4 Messaging](#) on page 17) until all voicemail messages have been listened to.

### 6.14.2 Check the Voicemail inbox

The voicemail is indicated by a "Voicemail message" icon  in the front of the voicemail message, and is also displayed first in the inbox list.

- 1 Enter "Messaging" menu, see [3.4 Messaging](#) on page 17
- 2 Select "Inbox".
- 3 Select the voicemail message.
- 4 Press "View".

5 Press "Call".

Voicemail is displayed with one entry in the message list regardless of the number of voicemail received.

### 6.14.3 One Key Voicemail Access

A long press on digit key "1" in standby mode calls voicemail. If the extension number is not available a dialog window "Voicemail number not defined" is displayed.

**Note:** Some systems require that the mailbox extension number is downloaded to the handset, refer to the Configuration Manual for the handset; see [17 Related Documents](#) on page 91.

## 7 Alarm Operation

NOTE: The support for the following system dependent features are dependent on what model of handset that is used. For more information, see [1.2 Functions and Accessories](#) on page 2. See also the Configuration Manual for the handset; see [17 Related Documents](#) on page 91).

IMPORTANT: If a shared phone is used, it must be logged in to the system to be able to send alarm. See [4.2 Log a Shared Phone On and Off](#) on page 22.

### 7.1 Push-button Alarm

Press the alarm button twice within two seconds to activate the alarm. An information text is displayed, default "Personal Alarm" is displayed. The alarm is sent to the alarm central that distributes it further. After that the handset returns to stand-by mode. Note that you can always trigger the alarm when you are speaking, editing your settings, or while the handset is locked.

### 7.2 Acoustic Location Signal

An alarm can be followed by an Acoustic Location Signal (ALS). The ALS is a signal from the handset that sounds for a predefined period of time. The signal is silenced by pressing the Mute button on the handset.

### 7.3 Test Alarm

Press and hold the alarm button until the information text is displayed, default "Test Alarm" is displayed.

### 7.4 Alarm with Location Information

Information about the handset's location can be sent along with an alarm. The location can be added as follows;

- Manually added by the user (see [7.4.1 Alarm with Data](#)) or,
- An approximately location given by the closest Base Station. refer to the Configuration Manual for the handset; see [17 Related Documents](#) on page 91
- A precise location given by DECT location devices. refer to the Configuration Manual for the handset.

#### 7.4.1 Alarm with Data

The data must manually be defined and stored by the user. To use the function, one Soft/ Hot key/Navigation key in the handset must be defined as a shortcut to the menu "Edit alarm data, see [8.3 Shortcuts](#) on page 59. The stored data is added to all types of alarm at transmission.

## 7.5 Automatic Call after Alarm

A handset can be setup to call a predefined number after an alarm has been sent. The number can also be dialled without sending an alarm by pressing a push-button that is not configured with alarm functionality. Depending on the settings, the call can be established in the following modes;

- Loudspeaking mode, or
- Monitor mode, or
- Normal mode

For more information, refer to the Configuration Manual for the handset; see [17 Related Documents](#) on page 91.

## 8 Menu Operation

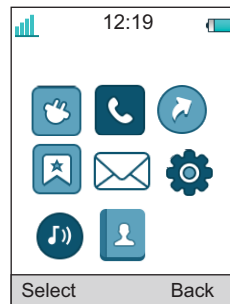



Figure 8. The main menu.

### 8.1 Connections

- 1 Enter the menu by pressing the "Menu" Soft key, or the confirmation button on the Navigation key.
- 2 Select  in the menu, and press the confirmation button or the Soft key "Select".

#### 8.1.1 Bluetooth

See also [Appendix A](#).

##### Enable Bluetooth Connection

- 1 Select "Bluetooth".
- 2 Select "Enable". A Bluetooth connection icon  is displayed in the header bar.

##### Disable Bluetooth Connection

- 1 Select "Bluetooth".
- 2 Select "Disable".

##### Pair/Connect Bluetooth Headset

In order to use a Bluetooth headset, it must first be paired with the handset. It is only needed to pair the Bluetooth headset once. A paired Bluetooth headset is automatically connected, which is indicated by a colored square  in front of the headset.

- 1 Set the Bluetooth headset in pairing mode, refer to the user manual for the Bluetooth headset.
- 2 Enable Bluetooth, see [Enable Bluetooth Connection](#).
- 3 Select "Bluetooth".
- 4 Select "Headset".
- 5 Select "Add new". An information text "Put headset in Pairing mode" is displayed.
- 6 Press "OK". It now searches for a Bluetooth headset for connection.
- 7 When headset is found, press "Pair".



- 8 If needed, enter PIN code, see user manual for the Bluetooth headset. Press "OK".  
The dialog *Successful pairing* appears if the pairing process was successful. The Bluetooth headset is also connected indicated by a colored square ■ in front of the headset.

**Tip:** The headset button can be configured with a specific function, such as post-dial, dial last called number, or dial a predefined number. For more information, refer to the Configuration Manual for the handset; see [17 Related Documents](#) on page 91.

### 8.1.2 Headset

In order to achieve optimal audio quality with the different headset types, it is recommended to select the corresponding headset profile.

The default setting is microphone on a boom, that is, the audio is optimized for using a headset with microphone on a boom. The headset profile can be changed in the menu by do as follows:

- 1 Select "Headset".
- 2 Select the corresponding headset profile from list, that is, "Mic on boom", "Mic on cable", "Hearing protection", or "Customized headset profile" (only visible if the headset profile has been configured in the WinPDM/Device Manager).
- 3 Press "Select".

### 8.1.3 System

The handset can subscribe up to eight different systems.



#### Change System

Select "Automatic" or a specific system. If the handset is set to "Automatic" it selects a system according to the priority list, see [Priority](#) on page 51.

#### Subscribe Handset in IP-DECT System using Easy Registration

A handset can subscribe to an IP-DECT system automatically if the following are fulfilled:

- The IP-DECT system is configured for Easy Registration, refer to the corresponding Installation and Operation manual for the IP-DECT system.
- The handset's IPEI is registered in the IP-DECT system, refer to the corresponding Installation and Operation manual for the IP-DECT system.
- The handset is not subscribed to any systems.

- 1 If needed, switch off the handset by pressing .
- 2 Switch on the handset by pressing .
- 3 Select language to be used or press "Cancel". If *Cancel* is pressed, the default language English is used.
- 4 The handset starts to search for IP-DECT systems. When a system is found the handset subscribes to it.

NOTE: If no system is found within 2 minutes or "Cancel" is pressed, the handset returns to the System menu. If this is the case, continue with [Subscribe Handset in DECT System Manually](#).

#### Subscribe Handset in DECT System Manually

To subscribe an DECT system manually, the "Park:" (Portable Access Right Key) and "Ac:" (Authentication code) related to the system are needed. Contact the system administrator for more information. If the handset has been subscribed in one system, additional systems have to be subscribed manually.

NOTE: The PARK code may not be needed if there is no alien DECT system within the coverage area.

The IPDI code is a unique code which has been assigned to the handset, see also [11.1 Admin Menu](#) on page 77.

- 1 Select "System".
- 2 Select "Subscribe".
- 3 Press "Next".
- 4 Enter System name (optional). If no system name is entered, the default name is used. That is System A, System B etc. depending on which system name that is free.
- 5 Press "Next".
- 6 Enter PARK code (max. 31 digits). The PARK code may not be needed if there is no alien DECT system within the coverage area.
- 7 Enter AC code. The AC code length must be between 4 - 8 digits.

- 8 Press "Next".
- 9 An information text "Protection on?" is displayed. Select "Yes" if the new system is to be protected.

NOTE: A protected system cannot be unsubscribed via the System menu. The unsubscription must be made via the Admin menu or the DECT system.

- 10 Press "OK". A searching mode starts.

### Unsubscribe System

- 1 Enter the menu by pressing the "Menu" soft key.
- 2 Select  in the menu.
- 3 Select "System".
- 4 Select "Unsubscribe".
- 5 Select the system to unsubscribe.
- 6 Press "Yes to unsubscribe the system."

### Rename System

The name of the system can be changed in the in the handset by performing these steps:

- 1 Select "Rename system".
- 2 Select system to rename and press the "Edit" soft key.
- 3 In the "Name" field, enter new name.
- 4 Select "Save".

### Priority

The default order of priority is the order of entered subscriptions. This means that the first subscribed system has the highest priority. This list can be edited by the user. The priority of a system can be modified by moving it up or down in the list.

NOTE: This is used in combination with system set to be "Automatic", see [Change System](#) on page 50.

- 1 Select "Priority".
- 2 Change the priority if needed by selecting "Up" or "Down". The priority is saved when "Back" is selected.

#### 8.1.4 In Charger Action when in Call

The behaviour of the handset placed in charger during a call can be set in one of the following ways:

- 1 Select "In charger".
- 2 Select "Call behavior".
- 3 Select one of the following:
  - No action - no action is performed when handset is placed in charger during a call.
  - Loudspeaking - The loudspeaker is activated when handset is placed in charger during a call.
  - End call - The call is disconnected when handset is placed in charger.

### 8.1.5 In Charger Action when not in Call

The behaviour of the handset placed in charger when not in call can be set in one of the following ways:

- 1 Select "In charger".
- 2 Select "Other actions".
- 3 Select one of the following:
  - No action - no action is performed when handset is not in call and placed in charger.
  - Change profile - when the handset is placed in the charger it changes profile. When the handset is removed from the charger, the profile is changed back. Press "Edit" and select the wanted profile. By default only the profile *Normal* is selectable, but additional profiles are visible if they are configured. See [8.6 Profiles](#) on page 64.
  - Switch off - When the handset is placed in the charger it switches off. When it is removed from the charger it switches on again. NOTE: If handset restrictions are enabled, the handset might not be switched off when placed in charger.
  - Sound off - When the handset is placed in the charger it is muted. When it is removed from the charger it switches the sound on again. When the handset is switched off in the charger, the Owner ID of the handset is still displayed. This simplifies the identification of the handset when, for example, it is being charged with other handsets. NOTE: If handset restrictions are enabled, the handset might not be silenced when placed in charger.
  - Logout - When the handset is placed in a charger it is logged off. Call list and message list are deleted when the handset is logged out. When it is removed from the charger, the user needs to log on again. NOTE: This feature is applicable in IP-DECT systems only. See also [4.2 Log a Shared Phone On and Off](#) on page 22.
  - Message absence - When an application or system sends a message to a handset, it receives an indication that the handset is absent. If a handset is absent, the application or system determines if the message is to be sent to the handset or not, or redirected to another handset.

NOTE: If a message is sent from a handset, it does not receive an indication that the recipient is absent. This function must be programmed in the PBX to be able to redirect calls and messages.

NOTE: Additional "In charger" actions to those listed above can also be configured. For additional information, refer to the Configuration Manual for the handset; see [17 Related Documents](#) on page 91.

## 8.2 Calls

- 1 Enter the menu by pressing the "Menu" Soft key, or the confirmation button on the Navigation key.
- 2 Select  in the menu, and press the confirmation button or the Soft key "Select".

### 8.2.1 Call List

The 25 last received, dialled or missed calls are stored in a call list. If a number occurs more than once the last time stamp, together with the total number of occurrences, is shown.

NOTE: If supported by the system, the number's contact name can be displayed in the call list.

NOTE: The handset can also be prevented from storing calls in the call list. This can, for example, be used to ensure privacy for users sharing the same handset. This feature requires configuration in the handset via WinPDM/Device Manager.

- 1 Select Call list. To scroll in the list, press up and down on the navigation key.

#### Dial number from Call list

- 1 Select number to call.
- 2 Press the soft key "Call" to dial.

#### View the Time of a Call

- 1 Press the Soft key "More".
- 2 Select "Time of call". The time and date is displayed.

#### Edit Number from Call list

- 1 Press the Soft key "More".
- 2 Select "Edit number".

#### Save Number

- 1 Press the Soft key "More".
- 2 Select "Save number".

#### Send Message

- 1 Press the Soft key "More".
- 2 Select "Send message".

#### Delete Entry from the Call list

- 1 Press the Soft key "More".
- 2 Select entry to delete.
- 3 Select "Delete".
- 4 Select "Yes" to delete the entry from the list.

#### Delete all Entries from the Call list

- 1 Press the Soft key "More".
- 2 Select "Delete all".
- 3 Select "Yes" to delete all the entries from the list.

### 8.2.2 Missed Calls

NOTE: The dialog window that appears for a missed call can be turned off. The handset can also be prevented from storing calls in the call list. The latter feature can for example be used to ensure privacy for users sharing the same handset. These features require configuration in the handset via WinPDM/Device Manager.

When a missed call dialog window is shown, the user can view the missed calls by pressing "Yes". If the user presses "No", the missed calls can be viewed as follows:

- 1 Enter the menu by pressing the "Menu" soft key, or the confirmation button on the Navigation key.
- 2 Select  in the menu, and press the confirmation button or the Soft key "Select".
- 3 Select "Missed calls". To scroll in the list, press up and down on the navigation key.
- 4 Press the Soft key "Call" to call back.

As in Call List there is a Soft key "More" which can be used to view the time/date of the call, edit the received number, add to contacts, delete received numbers. See [8.2.1 Call List](#) on page 53 for information about the functionality in Soft key "More".

NOTE: If supported by the system, the number's contact name can be displayed in the call list.

### 8.2.3 Call Time

The total time of the previous call and last call is displayed.

- 1 Select "Call time".

### 8.2.4 Push to Talk

NOTE: The support for this feature is dependent on what model of handset that is used. For more information, see [1.2 Functions and Accessories](#) on page 2.

The push-to-talk (PTT) function can be described as a group or conference call to a predefined group of members. If one of the group members wants to get in contact with the others, he or she presses and holds the PTT button  to open the microphone.

NOTE: The Multifunction button may also be configured to serve as the PTT button. This makes it easier for users who may have to wear gloves because of dress or other requirements. Because the multifunction button is larger than the PTT button and found on top of the handset, it is easier to locate and use compared to the smaller PTT button at the side of the handset.

The support for Multifunction button is dependent on what model of handset that is used. For more information, see [1.2 Functions and Accessories](#) on page 2.

NOTE: Some legacy systems/PBXs require that the handset sends a predefined DTMF tone when pressing/releasing . For more information, refer to the Configuration Manual for the handset; see [17 Related Documents](#) on page 91.

To participate in the conference, the group members must first accept an invitation received as an incoming call or as a text message. See [8.2.5 Accept an Invitation](#) on page 55.

If a member declines an invitation, he or she can re-join the group or conference later on. See [8.2.8 Re-join a Group](#) on page 57.

A user can also invite a group of members to participate in a conference call by calling a PTT group, see [8.2.7 Call a PTT Group](#) on page 57.

## 8.2.5 Accept an Invitation

### Accept Invitation Received as Incoming Call (PTT Basic)





A PTT invitation received as an incoming call is indicated by the  icon. In the dialogue window, a message containing maximum 24 characters can also be shown. See [figure 9](#).





Figure 9. Incoming Invitation Received as a Call

- 1 Press "Accept", or .  
Default the handset starts in inverted mute and loudspeaking mode, but it can be configured differently in a PTT group.
- 2 Press and hold  to open the microphone for transmitting. The microphone is muted again when  is released.
- 3 The Multifunction button may have also been configured to act as the  button.  
NOTE: The support for Multifunction button is dependent on what model of handset that is used. For more information, see [1.2 Functions and Accessories](#) on page 2.

### Invitation Received as Incoming Call during an Ongoing Call

If a user receives an invitation during an ongoing call, it is displayed as an ordinary invitation, see [figure 9](#) on page 55. The user can either accept or decline the invitation by pressing "Accept" or "Decline", respectively.

**Note:** The invitation cannot be accepted or declined by pressing  or , respectively.

If the user presses "Accept", the ongoing call is disconnected and the PTT call is connected.

Alternatively, the ongoing call can also be disconnected and the PTT call connected if the following is fulfilled:

- The handset is configured to answer invitations automatically
- The user does not respond to the invitation within 10 seconds
- The invitation has higher priority than the ongoing call

If the user declines the invitation, the he/she can re-join the PTT later on, see [8.2.8 Re-join a Group](#) on page 57.

### Accept Invitation Received as Message (PTT Advanced)

A PTT invitation received as a message is viewed the same way as an ordinary message. The message can contain up to 1000 characters. See [figure 10](#) on page 56.

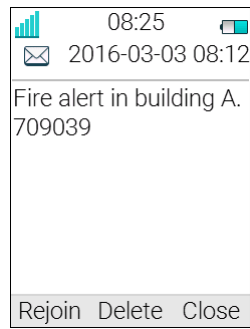

Figure 10. Incoming Invitation Received as a Message

- 1 Press "Accept".

The handset may accept the invitation automatically, start in inverted mute and loudspeaking mode, depending on the configuration of the received invitation.

When the invitation is accepted, the following screen appears (see [figure 11](#)). The invitation can now be deleted or closed by clicking the soft key Delete or Close, respectively. The call is not disconnected by clicking these soft keys. The soft key Call is used for re-joining a group only, see [8.2.8 Re-join a Group](#) on page 57.

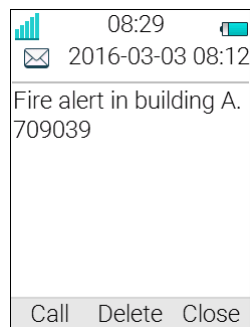





Figure 11. Accepted PTT Invitation

- 2 Press and hold  to open the microphone for transmitting. The microphone is muted again when  is released.
- 3 The Multifunction button may have also been configured to act as the  button. NOTE: The support for Multifunction button is dependent on what model of handset that is used. For more information, see [1.2 Functions and Accessories](#) on page 2.

### Invitation Received as Message during an Ongoing Call

If a user receives an invitation during an ongoing call, the call is disconnected and the PTT call connected if the following conditions apply:

- The handset is configured to answer invitations automatically
- The invitation is of higher priority than the call priority
- The user does not reject the invitation within 10 seconds

When the invitation is received, a warning signal notifies the user before disconnecting the current call in order to connect the PTT call.



NOTE: Depending on the priority of the invitation, the ongoing call might be disconnected immediately or after 10 seconds.

If the user rejects the invitation, it can be re-joined later on, see [8.2.8 Re-join a Group](#) on page 57.

### 8.2.6 Decline a PTT Invitation

#### Decline Invitation Received as Incoming Call



Press "Decline", or  to reject a PTT invitation. The handset returns to the previously shown screen. See also [8.2.8 Re-join a Group](#) on page 57.

#### Decline Invitation Received as Message

Press "Reject" to reject the invitation. The handset returns to the previously shown screen. See also [8.2.8 Re-join a Group](#) on page 57 for more information.

### 8.2.7 Call a PTT Group

NOTE: This option is only visible when PTT group(s) is defined, For more information, refer to the Configuration Manual for the handset; see [17 Related Documents](#) on page 91.

- 1 Press "Menu".
- 2 Select  in the menu.
- 3 Select "PTT groups".
- 4 Select PTT group.
- 5 Press "Call", or .

**Tip:** Alternatively, when in idle mode, press  quickly, select PTT group, and then press .

### 8.2.8 Re-join a Group

#### Re-join a Group from Call List

If a PTT invitation was received as a call and the user rejected or missed it, the PTT group can be dialed from the Call list or Missed calls, respectively. The PTT invitation is indicated by the  icon in the list. See [8.2.1 Call List](#) on page 53, or [8.2.2 Missed Calls](#) on page 54.

#### Re-join a Group from Messaging Inbox

If an PTT invitation was received as a text message and then rejected, the PTT group can be dialed by selecting the message indicated by the  icon in the Messaging inbox, and then press the soft key "Call". See [figure 11](#) on page 56.

### 8.2.9 Call Services

NOTE: These functions are system dependent. Besides the default Call services functions, 10 extra system specific call services can be defined - with or without automatic disconnection. The parameters are set up in the Portable Device Manager (WinPDM), refer to the Configuration Manual for the handset, and the Installation and Operational Manual for the Portable Device Manager (WinPDM), Windows version.

### Absence Handling

The reason for being absent and the return time can be specified here.

- 1 Select "Call services".
- 2 Select "Absence".
- 3 Select the applicable absence reason in the list. The number of absence reasons (for example "Lunch", "Meeting", "Trip" etc.) are configured in the WinPDM.

NOTE: The code is defined when configuring the absence reason in the handset. For more information, refer to the Configuration Manual for the handset; see [17 Related Documents](#) on page 91.

- 4 Press "Select".
- 5 Enter time (HHMM) or date (MMDD) depending on the selected absence reason.
- 6 Press "OK".

The handset sends an absence reason code to the system by establishing a call. The call is automatically disconnected after a few seconds.

### Deactivate the Absence Setting

- 1 Enter "Call service" in the menu.
- 2 Select "Deactivate".
- 3 Press "Select".

### Divert Calls

The user can divert calls to another extension.

- 1 Select "Divert calls".

### Divert Internal/External Calls

- 1 Select "Internal" or "External".
- 2 Select "Activate".
- 3 Enter number (maximum 24 digits) to divert to, or press the soft key  to open the phonebook.
- 4 Press "OK".

The handset sends a diversion reason code to the system by establishing a call. The call is automatically disconnected after a few seconds. The code is defined when configuring the diversion reason in the handset. For more information, refer to the Configuration Manual for the handset; see [17 Related Documents](#) on page 91.

To stop diversion select "Deactivate" and press the confirmation button or the Soft key "OK".

### Divert Calls if No Reply

- 1 Select "No reply".
- 2 Select "Activate".
- 3 Enter number (maximum 24 digits) to divert to, or press the soft key  to open the phonebook.
- 4 Press "OK".

The handset sends a diversion reason code to the system by establishing a call. The code is defined when configuring the diversion reason in the handset. For more information, refer to the Configuration Manual for the handset; see [17 Related Documents](#) on page 91. The call is automatically disconnected after a few seconds.

To stop diversion select "Deactivate" and press the confirmation button or the Soft key "OK".

### Divert Calls When Busy

- 1 Select "When busy".
- 2 Select "Activate".
- 3 Enter number (maximum 24 digits) to divert to, or press the soft key  to open the phonebook.
- 4 Press "OK"

The handset sends a diversion reason code to the system by establishing a call. The code is defined when configuring the diversion reason in the handset. For more information, refer to the Configuration Manual for the handset; see [17 Related Documents](#) on page 91. The call is automatically disconnected after a few seconds.

To stop diversion select "Deactivate" and press the confirmation button or the Soft key "OK".

## 8.3 Shortcuts

Predefined functions can be set as shortcuts for the Soft keys, Hot keys, Navigation keys and the Multifunction button. For example, a soft key can be set to make a call, as a shortcut to send a message or to a menu.

**Tip:** If creating a shortcut to the *Phone call* function, a variable or character *U* in the *Enter number* field can be added that lets the user enter additional numerical characters before calling the number. See [9 Procedure Call](#) on page 75 for more information.

- 1 Enter the menu by pressing the "Menu" Soft key, or the confirmation button on the Navigation key.
- 2 Select  in the menu, and press the confirmation button or the Soft key "Select".

### 8.3.1 Define Soft Keys

- 1 Select "Soft keys".
- 2 Select "Left", "Middle", or "Right".
- 3 Press "Select" to enter a name for the Soft key.
- 4 Press "OK".
- 5 Select "Function", and press "Select" to select function for the Soft key.
- 6 Select function from list, and press "Back".
- 7 Select "Value" (only for some of the functions), and press "Select". Enter a value for example a handset number. Press "Back".
- 8 Select "Control question", and press "Select". It is off by default. Press "Back".
- 9 Press "Save".

### 8.3.2 Define Hot Keys

- 1 Select "Hot keys".
- 2 Select "0", "2" to "9".
- 3 Select "Function", and press "Select" to select function for the Hot key.
- 4 Select function from list, and press "Back".
- 5 Select "Value" (only for some of the functions), and press "Select". Enter a value for example a handset number. Press "Back".
- 6 Select "Control question", and press "Select". It is off by default.
- 7 Press "Save"

### 8.3.3 Define Navigation Key

- 1 Select "Navigation keys".
- 2 Select "Up", "Down", "Left", or "Right".
- 3 Select "Function", and press "Select" to select function for the Navigation key.
- 4 Select function from list, and press "Back".
- 5 Select "Value" (only for some of the functions), and press "Select". Enter a value for example a handset number. Press "Back".
- 6 Select "Control question", and press "Select". It is off by default.
- 7 Press "Save".

### 8.3.4 Define Multifunction

NOTE: The support for this feature is dependent on what model of handset that is used. For more information, see [1.2 Functions and Accessories](#) on page 2.

The Multifunction button can be defined with two different functions, a long press activates one function, and a double press activates another function.

- 1 Select "Multi-function button".
- 2 Select "Long press", or "Multi press".
- 3 Select "Function", and press "Select" to select function.
- 4 Select function from list, and press "Select" and then press "Back".
- 5 Select "Value" (only for some of the functions), and press "Select". Enter a value for example a handset number. Press "Back".
- 6 Select "Control question", and press "Select". It is off by default.
- 7 Press "Save".

## 8.4 Services

The Services menu lets the user create a submenu of frequently used functions. For example, "Write new message", "Central phonebook", "Call contact", etc.

**Tip:** If configuring the *Phone call* function, a variable or character *U* in the Enter number field can be added that lets the user enter additional numerical characters before calling the number. See [9 Procedure Call](#) on page 75 for more information.

- 1 Enter the menu by pressing the "Menu" Soft key, or the confirmation button on the Navigation key.

- 2 Select  in the menu, and press the confirmation button or the Soft key "Select".

#### 8.4.1 Add Services

- 1 Select "Add new" from the "Services" menu.
- 2 Choose an appropriate name for the service and enter the name in the "Name" field.
- 3 Press "OK". The "Function" menu is displayed.
- 4 To navigate to the required function, press up and down on the navigation key.
- 5 Press "Select" or the confirmation button on the navigation key.
- 6 If necessary, enter values in the fields (only applicable for some of the functions)
- 7 Press "Back".

#### 8.4.2 Edit Services

- 1 Mark a service by pressing up and down on the navigation key.
- 2 Press "More"
- 3 Select "Edit".
- 4 Edit the service parameters.
- 5 Press "Back"

#### 8.4.3 Delete Services

- 1 Mark a service by pressing up and down on the navigation key.
- 2 Press "More".
- 3 Mark "Delete" by pressing down on the navigation key.
- 4 Press "Select".
- 5 Press "Yes" to delete the service.

### 8.5 Messaging

**Tip:** To close several new messages quickly, press . The messages are indicated as unread messages in the Messaging inbox.

The thirty last received messages are stored in the inbox. Time and date information is included in the message.

If a message is received when the inbox already contains thirty messages, the message in the inbox with the oldest time and date is automatically replaced by the newly received message.

**Tip:** New messages and information about incoming calls can be displayed upside down. This can be useful if the handset is worn in a belt and the user wants to read the message or call information without rotating the handset. When pressing any key, the messages is displayed in the normal way. For more information, refer to the Configuration Manual for the handset; see [17 Related Documents](#) on page 91.

- 1 Enter the menu by pressing the "Menu" Soft key, or the confirmation button on the Navigation key.
- 2 Select  in the menu, and press the confirmation button or the Soft key "Select".

### 8.5.1 Inbox

- 1 Select "Inbox" to view the message list.
- 2 Select a message by pressing up and down on the navigation key.

#### Reply to Sender

- 1 Select "View".
- 2 Select "Reply".
- 3 Enter text.
- 4 Select "Send".

#### Delete Message

- 1 Select "More".
- 2 Select "Delete".
- 3 Select "Yes" to delete the message.

#### Forward Message



- 1 Select "More".
- 2 Select "Forward".
- 3 Enter additional text if needed.
- 4 Select "Send".
- 5 Enter number.
- 6 Select "Send" to forward the message.

#### Call Sender

- 1 Select "View".
- 2 Select "More".
- 3 Select "Call Sender".

#### Call number in Text

NOTE: This option is only visible if the number consists of minimum 3 digits.

- 1 Select "View".
- 2 Do one of the following:
  - Press "More" and select "Call no. in text".
  - Press .
- 3 If the message contains several numbers, select the number to be called from the list.
- 4 Press "Call", or .

#### Save Number

- 1 Select "View".
- 2 Select "More".
- 3 Select "Save number".
- 4 Select "Work Number"/"Mobile number"/"Other number".
- 5 Press "Add".

- 6 Enter name for the contact.
- 7 Press "OK".
- 8 Press "Save". The number is saved in the contact list.

### **8.5.2 Write New Messages**

- 1 Select "Write new message".
- 2 Enter text, and press "Send". See also [6 Messaging](#) on page 35.  
The message can be saved and sent later by pressing the soft key "Back" and selecting "Yes". The message is stored under Unsent messages. See [8.5.3 Unsent Messages](#).
- 3 Enter number, or press middle soft key to get number from contact list.
- 4 Press "Send".

### **8.5.3 Unsent Messages**

- 1 Select "Unsent" to view the list.
- 2 Select message to edit/send.
- 3 Select "Edit", edit text and/or just select "Send".  
Delete/Delete All
- 1 Select "More".
- 2 Select "Delete" or "Delete all".
- 3 Select "Yes" if the unsent message shall be deleted.

### **8.5.4 Sent Messages**

- 1 Select "Sent" to view the list.
- 2 Select "View".

#### **Forward message**

- 1 Enter additional text if needed.
- 2 Enter number.
- 3 Select "Send".

#### **Delete Message**

- 1 Select "Delete".
- 2 Select "Yes" to delete the message.

#### **Delete/Delete All**

- 1 Select "More".
- 2 Select "Delete" or "Delete all".
- 3 Select "Yes" if the unsent message shall be deleted.

## 8.6 Profiles

An own profile can be set up for incoming calls, message alerts, message volume, vibrating alerts, key sound etc. This can be useful when there are many users on the same handset who require different sound profiles. It can also be used for temporarily settings, for example while in a meeting incoming calls should be silent. A user can then switch to his or her own particular profile when using the handset.

If no profile is selected, the normal settings are used.

NOTE: The settings in a profile can be superseded if the corresponding settings in a system profile are activated. When the system profile is activated, its settings are not displayed in the handset menu. However, they can be displayed when a system profile is activated in the handset. See [10 System Profiles](#) on page 76.

- 1 Enter the menu by pressing the "Menu" Soft key, or the confirmation button on the Navigation key.
- 2 Select  in the menu.

### Add New Profile

- 1 Enter the menu by pressing the "Menu" Soft key, or the confirmation button on the Navigation key.
- 2 Select  in the menu.
- 3 Select "Add new".
- 4 Enter name of the profile.
- 5 Press "Save".
- 6 Press "More" and then select "Add setting".
- 7 Select the setting you want to add to the profile.  
Repeat steps 6-7 if you want to add additional settings.
- 8 Mark the wanted setting and press "Edit" to make the changes.

A new profile based on another profile can also be created in the following way:

- 1 Enter the menu by pressing the "Menu" Soft key, or the confirmation button on the Navigation key.
- 2 Select  in the menu.
- 3 Select "Add new".
- 4 Enter name of the profile.
- 5 Press "Save".
- 6 Press "More" and then select "Import from".
- 7 Select the profile which settings to be used for the new profile.
- 8 If needed, press "More" and then select corresponding option to add/import additional settings or remove settings.



### Activate Profile

- 1 Enter the menu by pressing the "Menu" Soft key, or the confirmation button on the Navigation key.
- 2 Select  in the menu.
- 3 Select profile from list.

When a profile is activated, the icon  and the name of the profile are displayed in idle mode.

### Delete Profile

- 1 Enter the menu by pressing the "Menu" Soft key, or the confirmation button on the Navigation key.
- 2 Select  in the menu.
- 3 Select profile from list.
- 4 Press "More".
- 5 Select "Delete" from menu.
- 6 Press "Select".
- 7 Press "Yes" to confirm.

### Edit Profile

- 1 Enter the menu by pressing the "Menu" Soft key, or the confirmation button on the Navigation key.
- 2 Select  in the menu.
- 3 Select the profile to edited.
- 4 Press "More" and then select "Edit".
- 5 Following options can be performed:
  - Edit the wanted setting by marking it and then press "Edit".
  - Add additional settings by pressing "More" and then select "Add setting" or "Import from".
  - Remove a setting by marking it and then select More > Remove setting.
- 6 If needed, mark the added settings and press "Edit" to make the changes.

## 8.7 Contacts

The handset has a phonebook with 250 entries where the user can add, delete, and edit names and numbers. The phonebook lists all names in alphabetical order, where three numbers can be added for each contact; work number, mobile number, and other number.

In addition, a company phonebook with up to 1000 entries can be downloaded to the handset via the WinPDM/Device Manager. The company phonebook name and numbers can not be edited or deleted by the user. The phonebook lists all names in alphabetical order. The local and company phonebook appears in the same list but the company names are indicated by an icon  in front of the name. The contact only includes work numbers. See [5.3.9 Dial a Number from the Company Phonebook](#) on page 27 for more information.

A central phonebook can also be accessed, see [5.3.8 Dial a Name from the Central Phonebook](#) on page 27. This feature is a system dependent feature.

TIP: When searching for a contact, the input language can be temporarily changed by long pressing . This can be used to temporarily access characters in a foreign language.

- 1 Enter the menu by pressing the "Menu" Soft key, or the confirmation button on the Navigation key.
- 2 Select  in the menu, see [3.2 Contacts](#) on page 16.

### 8.7.1 Call Contact

- 1 Select "Call contact".
- 2 Select contact from the list, or enter name or number in the search field.
- 3 Press the Soft key "Call".

The contact can also be edited and a message sent by selecting "View" > "More".

### 8.7.2 Add Contact

- 1 Select "Add contact".

#### Add New Contact

- 1 Select "New".
- 2 Select "Add", and enter the name of the contact.
- 3 Press "OK".
- 4 Select "Work Number"/"Mobile number"/"Other number".
- 5 Press "Add".
- 6 Enter handset numbers.

**Tip:** A variable or the character *U* can be added to the Work/Mobile/Other number field to allow the user to enter additional numerical characters before calling the number. See [9 Procedure Call](#) on page 75 for more information.

- 7 Press "OK".
- 8 Press "Save".

NOTE: A specific ring signal can be set for each contact, see [8.7.3 Edit Contact](#) on page 67

#### Add from Call List

- 1 Select "From call list".
- 2 Select number.
- 3 Press "Add".
- 4 Select number type.
- 5 Press "Select".
- 6 Press "Add", and enter name for the contact.
- 7 Press "OK".
- 8 Press "Save".

NOTE: A specific ring signal can be set for each contact, see [8.7.3 Edit Contact](#) on page 67

### 8.7.3 Edit Contact

- 1 Select "Edit contact".
- 2 Select contact, and press "Edit" twice.
- 3 Enter new name/number, and press "OK".

**Tip:** A variable or the character *U* can be added to the Work/Mobile/Other number field to allow the user to enter additional numerical characters before calling the number. See [9 Procedure Call](#) on page 75 for more information.

- 4 Press "Save".

### 8.7.4 Set Ring Signal for a Contact

A specific ring signal can be set for each contact.

- 1 Add/edit a contact according to [8.7.2 Add Contact](#) on page 66 or [8.7.3 Edit Contact](#) on page 67.
- 2 Select "Ring signal"
- 3 Select the ring signal to be used for the selected contact.
- 4 Press "Back" and the press "Save".

### 8.7.5 Delete Contact

- 1 Select "Delete contact".
- 2 Select contact, and press "Delete".
- 3 Press "Yes" to confirm.

### 8.7.6 Central Phonebook

In the Central Phonebook can be searched by name or number. The last search result can be displayed.

When the search result is returned the contact information can be viewed. A number can be assigned to the new contact and a message sent by selecting the "More" soft key. The number can also be called by selecting the "Call" soft key.

- 1 Select "Central phonebook".

#### Search by Name

- 1 Select Search by name.
- 2 Enter First name and/or Last name.

TIP: When searching for a contact, adding and editing a contact, the input language can be changed temporarily by long pressing  $\times \uparrow \downarrow$ . This can be used to temporarily access characters in a foreign language.

- 3 Select "Search". The search result is displayed.

#### Search by Number

- 1 Select "Search by number".
- 2 Enter handset number, select "Search". The search result is displayed.

### View Last Search Result

- 1 Select "Last result". Only the last result is displayed.

## 8.8 Settings

- 1 Enter the menu by pressing the "Menu" Soft key, or the confirmation button on the Navigation key.
- 2 Select  in the menu, see [3.8 Settings](#) on page 20.

### 8.8.1 Sound and Alert Settings

#### Adjust the Ring Volume

- 1 Select "Sound & Alerts".
- 2 Select "Volume".
- 3 To increase the volume, press right on the navigation key. To decrease the volume, press left on the navigation key. Press Back to save the setting.

NOTE: If a handset restriction is enabled, it might not be possible to set the ring volume to "Silent". refer to the Configuration Manual for the handset; see [17 Related Documents](#) on page 91.

#### Set different Ring Signals for Calls

- 1 Select "Sound & Alerts".
- 2 Select "Ring signals".

Different signals for internal calls, external calls and call back can be set.

- 3 Select "Internal call", "External call", "Callback" or "PTT". The handset has 14 different ring signals.
- 4 Select sound. To listen to the different sounds, press "Play".

NOTE: Additional ring signals might be selectable if they are configured via WinPDM. For more information, refer to the Configuration Manual for the handset; see [17 Related Documents](#) on page 91.

- 5 Press "Back".

#### Set Alerts for Messages

- 1 Select "Message alert". Different message alerts can be selected. The handset has 8 different message alerts by default, see [3.8 Settings](#) on page 20.
- 2 Select message alert from list. Press "Play" to listen to the different sounds.

TIP: The option *Custom sounds* should be selected to create a customized message alert. For more information, refer to the Configuration Manual for the handset; see [17 Related Documents](#) on page 91.

NOTE: The "Play" soft key is not available for Enhanced beep and Custom sound. Instead, send a message to the handset to listen to the sound.

- 3 Press "Back".

TIP: By default, the message volume follows the ring volume setting. However, a different message volume can be set if required. refer to the Configuration Manual for the handset; see [17 Related Documents](#) on page 91.

### Turn the Vibrator On or Off

If the vibrator is activated, it vibrates on incoming calls and messages. In addition, the vibrator can also be activated when receiving a message during a call. For more information, refer to the Configuration Manual for the handset; see [17 Related Documents](#) on page 91.

- 1 Select "Vibrator alert". Choose between "On", "On if silent" (that is, the vibrator is on when the handset is muted), or "Off".
- 2 Select vibrating alert.
- 3 Press "Back".

### Set the Key Sound

This means that every time a key is used, the handset gives a small sound.

- 1 Select "Key sound". Choose between "Silent", "Click", or "Tone".
- 2 Select key sound.
- 3 Press "Back".

To listen to the key sound, press the soft key "Play".

## 8.8.2 Keypad Lock Settings

The handset keypad can be locked automatically to minimize the risk of accidentally pressing keys or buttons while the handset is not in use. The keypad is automatically locked after a lock time parameter "Auto lock time" expires.

NOTE: The alarm button can be pressed while the keypad is locked. Any one of five predefined emergency numbers can also be called while the keypad is locked as long as this feature has been configured in the WinPDM/Device Manager. For additional information, refer to the Configuration Manual for the handset; see [17 Related Documents](#) on page 91.

The automatic key lock can be configured by the administrator in the WinPDM/Device Manager. For additional information, refer to the Configuration Manual for the handset; see [17 Related Documents](#) on page 91. The user may also configure the automatic key lock as described in the following sections.

Automatic key lock: One of the following options may be configured:

"On": the keypad is automatically locked if it is not used before the specified lock time elapses.

"On, except calls": the keypad is automatically locked if it is not used for the specified lock time. If the user is in call when the lock time elapses, the keypad remains unlocked until the user has completed the call.

"Off": the keypad is never automatically locked.

Auto lock time: specifies the time that elapses before the keypad is automatically locked. The shortest time that may be specified before the key lock is applied is 5 seconds and the longest time is 3 minutes.

Auto key unlock: the keypad is automatically unlocked when a call or message is received. When the user has serviced the call or message, the key lock is reapplied after the specified automatic lock time expires.

### Activate the Automatic Key Lock

The user activates the automatic key lock and sets the Auto lock time from the handset "Settings" menu in the following way:

- 1 Select "Locks". The "Locks" menu is displayed.
- 2 Select "Automatic key lock" menu item and select "On" or "On except calls".  
NOTE: The current key lock setting is displayed under the "Automatic key lock" menu item.
- 3 Press the "Back" soft key to redisplay the "Locks" menu.
- 4 Select "Auto lock time" and press the "Select" soft key.
- 5 Select the required lock time and press the "Select" soft key.

### Deactivate the Automatic Key Lock

- 1 Select "Locks". The "Locks" menu is displayed.
- 2 Select "Automatic key lock" and select "Off".

### Automatic Key Unlock

The user can configure a locked keypad to unlock automatically when a call or message is received. After the user has serviced the call or message, the keypad is locked again after the specified Auto lock time expires.

## 8.8.3 Phone Lock Settings

The handset can be protected for unauthorized use by activating the phone lock. The phone lock may be set to:

- "On": The handset is automatically locked if not used for the specified automatic lock time or when it is first turned on.
- "On in charger": The handset is locked immediately when placed in the charger. When removed from the charger and unlocked by the PIN, the handset remains unlocked
- "Off": The handset is never locked.

The default phone lock PIN code (0000) can be changed to any 4 to 8 digit personalized code.

The length of time before the handset locks automatically is set by the "Auto lock time" parameter. The shortest time that can be set before the handset locks is 5 seconds and the longest time is 3 minutes.

NOTE: If configured in the WinPDM/Device Manager, any one of up to five emergency numbers can be called while the handset is locked. refer to the Configuration Manual for the handset; see [17 Related Documents](#) on page 91.

### Activate the Phone Lock

The phone lock settings are activated from the handset "Settings" menu in the following way:

- 1 Select "Locks".
- 2 Select "Phone lock".
- 3 Select "Auto phone lock".
- 4 Select "On" or "On in charger" as required.

- 5 Enter PIN code.
- 6 Press "OK".
- 7 Press the "Back" soft key twice to return to the "Locks".
- 8 Select "Auto lock time".
- 9 Select the required lock time.

If the PIN code has been forgotten, it can be removed by the handset distributor.

### **Deactivate the Phone Lock**

From the handset "Settings" menu:

- 1 Select "Locks".
- 2 Select "Phone lock".
- 3 Select "Auto phone lock".
- 4 Select "Off".
- 5 Enter PIN code.
- 6 Press "OK".

### **Change PIN Code**

From the handset "Settings" menu:

- 1 Select "Change PIN code".
- 2 Enter the old PIN code.
- 3 Press "OK".
- 4 Enter new PIN code twice.
- 5 Press "Save".

## **8.8.4 Display Settings**

### **Screen Saver**

The screen saver can be set to one of the following settings:

- Information: Displays status and identification information while the handset is idle.
- Black: The screen is black when the handset is idle.
- Black also in call: The screen is also black when the handset is in call.

To set the screen saver:

- 1 Select "Display" from the handset menu.
- 2 Select "Screen saver". The current setting is displayed under "Screen saver".
- 3 Select "Information", "Black", or "Black also in call".
- 4 Press "Back".

NOTE: When the handset with the screen saver set to "Information" is in a charger, the Owner ID is displayed even if the handset switched off. This simplifies identification when many handsets are in a charging rack.

### **Brightness**

- 1 Select "Display".
- 2 Select "Brightness".
- 3 Select "Normal" or "Power save".
- 4 Press "Back".

### **Rotate display text**

- 1 Select "Display".
- 2 Select "Rotate display text".
- 3 Select "Normal" or "Inverted".
- 4 Press "Back".

### **Font style**

- 1 Select "Display".
- 2 Select "Font style".
- 3 Select "Normal" or "Bold".
- 4 Press "Back".

## **8.8.5 Time and Date Settings**

The time and date displayed in the handset cannot be changed by the user. The DECT system is solely responsible for keeping the time. The handset also synchronises with the DECT system time when:

- The handset is turned on after having been turned off. The handset requests the current DECT system date and time.
- The handset remains on for longer than 24 hours. The handset requests the DECT system time every 24 hours from the time it was last turned on.

The time and date formats displayed in the handset can be changed by the user as described in the following sections.

### **Set Time Format**

- 1 Select "Time & Date" and press "Select".
- 2 Select Time format. The actual time format is displayed. Selectable time format:
  - 12:00 (AM/PM)
  - 24:00
- 3 Press "Select" to save the setting.

### **Set Date Format**

- 1 Select "Time & Date" and press "Select".
- 2 Select "Date format", press "Select". Selectable date format:
  - DD/MM/YYYY, for example, 17/09/2016 (also called Europe)
  - MM/DD/YYYY, for example, 9/17/2016 (also called US)
  - YYYY-MM-DD, for example, 2016-09-17 (ISO 8601)



- MMM DD YYYY, for example, Sep 17 2016
- DD MMM YY, for example, 17 Sep 16
- DD.MM.YYYY, for example, 17.09.2016
- DD-MM-YYYY, for example, 17-09-2016

3 Press "Select" to save the setting.

### 8.8.6 Answering

The default setting for the handset is to use the Off-hook key to answer a call. However, the handset can be configured to answer the call automatically, that is, without pressing a key and in loudspeaking mode if required. Other keys can also be setup to answer a call. If "Any key" is selected, any key, except the On-hook key and the Sound off key, can be used to answer a call

- 1 Enter  in the menu, see [3.8 Settings](#) on page 20.
- 2 Select "Answering".

#### Answering Key

The answering key is by default set to Hook-off.

- 1 Select "Answering key"
- 2 Select "Hook-off" or "Any key".

Press "Back" to save the setting.

#### Answering Behaviour

- 1 Select "Answering behaviour".
- 2 Select "Automatically" and/or "Loudspeaking".
- 3 Press "Change" to change the setting. The check box is marked.
- 4 Press "Back" to save the setting. To remove the setting, press "Change". The check box is unmarked.

### 8.8.7 Change Text size for Messages

- 1 Select "Messages".
- 2 Select "Text size Normal". The default text size is "Normal".
- 3 Select "Normal" or "Large".

### 8.8.8 Change the Menu Language

- 1 Select "Language". Choose between; Brazilian Português (Brazilian Portuguese), Czech, Dansk (Danish), Deutsch (German), English, Español (Spanish), Français (French), Greek, Hungarian, Italiano (Italian), Nederlands (Dutch), Norska (Norwegian), Polish, Russian, Slovakian, Soumi (Finish), Svenska (Swedish), and Turkish.
- 2 Press "Back".

NOTE: In addition to the languages listed above, an additional language can be downloaded to the handset, see [12.1 Software Upgrade and Additional Features](#) on page 78.

### **8.8.9 Change Owner ID**

The Owner ID is set to identify the handset.

- 1 Select "Owner ID".
- 2 Enter identity.
- 3 Press "Save".

## 9 Procedure Call

When configuring the functions Call services, In Call menu, Contacts, or a shortcut or service to the *Phone call* function, the data added in these functions is static. When entering the data for the function to be used, a variable or character *U* can be entered that allows the user to enter additional numerical characters before calling the number or sending the data to a system.

NOTE: The Call services and In call menu features require configuration in WinPDM/Device Manager.

refer to the following example for more information.

Example of configuration:

A user wants to create a service with the *Phone call* function. The PBX requires that a prefix must be added to a phone number. In this case, the user can pre-program the prefix and then enter the applicable phone number when using the *Phone call* function.

- 1 Press "Menu", or the confirmation button.
- 2 Select "Services".
- 3 Select "Add new".
- 4 In the *Name* field, enter "Call no." and press the "OK" soft key.
- 5 Select the function "Phone call".
- 6 In the *Number* field, enter the prefix to be used followed by the character "U". In this case, the text string is as follows \*21\*U. The character *U* represents an *Enter number* dialog where the user can enter the phone number.
- 7 Press "Save".

When using the function, an *Enter number* dialog appears, see [figure 12](#). If the user enters "123" (or selects a contact with this number by pressing ) and presses "OK", the number \*21\*123 is dialled. Note that no call is established before the user presses "OK", that is, post-dial.

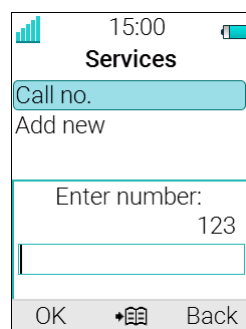

Figure 12. Enter number dialog.

## 10 System Profiles

NOTE: The support for this feature is dependent on what model of handset that is used. For more information, see [1.2 Functions and Accessories](#) on page 2.

A system profile can be used when certain settings in a handset are required that the user is not allowed to change. The settings require configuration in the WinPDM or Device Manager and include alarm settings, soft key settings and presence settings. For additional information, refer to the Configuration Manual for the handset; see [17 Related Documents](#) on page 91. When the system profile is activated, its settings is not displayed in the handset's menu. It can be shown that a system profile is active in the handset by showing its profile name in idle mode.

The system profile can be used in combination with the user profile (see [8.6 Profiles](#) on page 64). If there is conflict between the settings in the system profile and the settings in the user profile, the settings in the system profile is used.

If a user changes a setting in the handset menu that is determined by a system profile, the menu is updated but the setting is not changed.

For example, in the left-hand view of [figure 13](#), a system profile has been activated and is indicated by the system profile name "Sys Profile SK1" shown in the handset in idle mode. In this case, the soft key "Inbox" and middle soft key "PTT 4" are determined by the system profile settings. If a user, for example, attempts to change the middle soft key name to "PTT 5", by using the handset menu Shortcuts > Soft keys > Middle (middle view in figure), the soft key shows "PTT 5" and the setting can be saved. However, the system profile settings are not overridden. When the handset returns to idle mode, the system profile settings are redisplayed, showing "PTT 4" instead of the user changed "PTT 5" (right-hand view in figure).

**Tip:** If this system profile is to be permanently activated, it is recommended to hide the *Soft keys* menu in the handset.

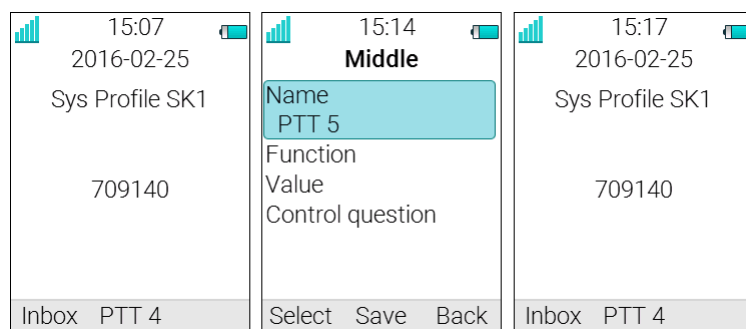

Figure 13. System profile overrides settings changed by the user.

### 10.1 System Profile Status Indications

The administrator may configure the handset to play a sound if the system profile is activated or deactivated. This provides the user with an audible alert when the system profile changes from inactive to active or vice versa.

The feature can be triggered by several kinds of event, such as moving between different parts of a buildings where a system profile might be appropriate in one location but not required in another. The system profile name is displayed when the handset is in idle mode. The user should be aware that the characteristics and behaviour of the handset change when the system profile changes. For the exact sound and characteristics of the handset

associated with the activation and deactivation of a system profile, refer to the system administrator.

## 11 Advanced Functions

### 11.1 Admin Menu

The handset has a hidden menu for system administrators. refer to the Configuration Manual for the handset; see [17 Related Documents](#) on page 91.

The Admin menu contains:

- Software and hardware information, licence information, IPEI/IPDI, and User ID
- DECT link and system information
- DECT location information. NOTE: The support for this feature is dependent on what model of handset that is used. For more information, see [1.2 Functions and Accessories](#) on page 2.
- Centralized Management status
- Site survey tool
- Fault logging
- Enhanced system menu with ability to alter protection
- Frequency band selection (this option is removed when the frequency band has been selected)
- Factory reset option

For quick access to the Device Information (DI) menu in idle mode, press the keys containing \*#DI# (that is \*#34# ). For quick access to the IPEI/IPDI, press \*#06# in idle mode. refer to the table below.

Information	Code
Software version	*#34#
Hardware version	*#34#
License information	*#34#
IPEI/IPDI	*#34# or *#06#
User ID	*#34#

### 11.2 Clear Lists in Charger

A parameter can be set via the WinPDM/Device Manager to clear message and call lists stored in the handset. When the parameter is activated and the function has been downloaded to the handset, the lists are deleted when the handset is placed in a charger. This can be useful during administration of handsets for new users. See also the Configuration Manual for the handset; see [17 Related Documents](#) on page 91).

## 12 System Handling

### 12.1 Software Upgrade and Additional Features

Software and parameters in the handset can be upgraded by using the WinPDM or the Device Manager. refer to the Installation and Operation Manual for the Portable Device Manager (WinPDM) Windows Version, or the Installation and Operation Manual for the Device Manager.

Examples of additional features that can be downloaded/configured via WinPDM/Device Manager:

- Company phonebook
- Downloadable languages
- Customizing the Menu Tree

For more information, refer to the Configuration Manual for the handset; see [17 Related Documents](#) on page 91.

To view the handset's software version, enter \*#34# in idle mode.

### 12.2 Handset Updates via Charging Rack

From time to time, users are instructed to leave their handsets in a central charging rack to allow the handset to be updated with new features and functions. An ongoing update is indicated by the  in the handset header bar and an "Updating handset" message is displayed in the active area.

During the update, a message is displayed to indicate that an update is in progress as shown in [figure 14](#). The "OK" soft key can be selected to close the message.

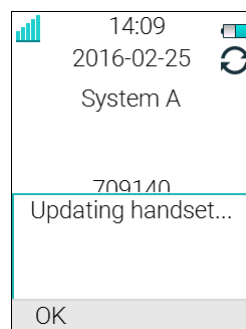
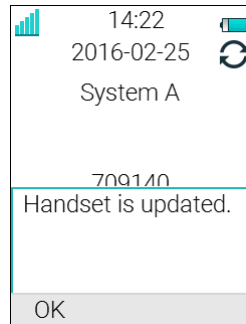

Figure 14. Handset Update while in Charger

If the handset removed from the charger and used, the update is suspended and resumed when it is returned to the charger.

When the update is complete, a "Handset is updated" message is displayed to indicate that the handset is available for use, as shown in [figure 15](#). Select the "OK" soft key to close the message.



*Figure 15. Update Completed while in Charger*

## 13 Troubleshooting

This section contains information on how to solve common operational problems, and warnings you may receive.

Go through the following lists if you encounter any problems. If this checklist does not solve the problem, contact your system administrator.

If others have similar problems, there may be a system error.

### Operational Problems

<b>Fault</b>	<b>Probable cause</b>	<b>Action or comment</b>
No display	The battery level is low The screen saver is set to "Black also in call"  The handset is defective.	Charge the battery Change the screen saver setting as described in <a href="#">Screen Saver</a> on page 71 Contact system administrator.
No ringing	The sound off icon is on, or ring volume set to silent, or the handset is defective.	Long press the Sound off key, or increase volume, or contact system administrator.
Unable to mute handset by long pressing Sound off key/Mute button.	A handset restriction preventing the user to silence the handset.	Enable the parameter <i>Possible to turn off sound</i> see Configuration Manual, DH7 DECT Handset, TD 93190EN.
Unable to set the ring volume to "Silent".		
Handset, with <i>In Charger &gt; Other actions&gt;Sound off</i> enabled, is not muted when placed in charger.		
Unable to switch off handset by long pressing the On-hook key.	A handset restriction preventing the user to switch off the handset.	Disable the parameter <i>Prevent switch off</i> , see Configuration Manual, DH7 DECT Handset, TD 93190EN.
Handset, with <i>In Charger &gt; Other actions&gt; Switch off</i> enabled, is not switched off when placed in charger.		
Unable to subscribe handset using Easy Registration feature.	1) The handset is subscribed to a system.	1) Unsubscribe the handset and then subscribe it by following the instructions in <a href="#">Subscribe Handset in DECT System Manually</a> on page 50.



<b>Fault</b>	<b>Probable cause</b>	<b>Action or comment</b>
	2) The IP-DECT system is not configured for Easy Registration.	2) Subscribe the handset manually, see <a href="#">Subscribe Handset in DECT System Manually</a> on page 50,  or  configure the system to support Easy Registration, refer to the applicable Installation and Operation Manual for your IP-DECT system.
	3) There is ambient equipment disturbing your IP-DECT system.	3) Try to subscribe the handset in other area in your building.
		4) If the problem still exists, restart your handset and subscribe the handset.

**Error or Warning Messages**

<b>Display shows</b>	<b>Probable cause</b>	<b>Action or comment</b>
No access	The network is in range, but no access rights.	Switch handset off and then switch it on again or contact system administrator.
No System. The handset beeps once a minute (during max 30 minutes) with a low tone followed by a high tone (if enabled, the vibrator also follows the beeps).	The handset is out of coverage or handset is defective.	Stop the beep with the Sound off key and go into range. Note: When re-entering the coverage area it can take a couple of minutes before the handset automatically has registered into the system. or contact system administrator.
The message Failed is displayed when the handset tries to download an ECG waveform image.	The IP-DECT wireless connection point is overloaded with too many calls.	Go refer to the patient. The ECG Monitoring functionality starts working when the IP-DECT connection point is no longer overloaded.
SERVICE NEEDED Parameters corrupt	The handset is defective.	Send the handset for service.
Note: This display message is only shown in English.		

<p>SERVICE NEEDED Invalid IPDI</p> <p>Note: This display message is only shown in English.</p>	<p>Easy replacement procedure not followed correctly or failure during easy replacement procedure.</p>	<p>Send the handset for service.</p>
<p>Enter PIN code</p>	<p>The handset's lock is activated.</p>	<p>Enter the required PIN code. If PIN code lost enter new via WinPDM or do a factory reset via WinPDM.</p>
<p>Battery low, charge now</p>	<p>The battery level is low.</p>	<p>Charge or replace the battery.</p>
<p>Phonebook is not available at the moment.</p>	<p>The phonebook does not respond, not available at the moment.</p>	<p>Try again later or if fault persists do a factory reset via admin menu or WinPDM.</p>
<p>Voicemail number not defined</p>	<p>There is no Voicemail number defined in the handset.</p>	<p>Define a Voicemail number via WinPDM.</p>
<p>Could not encrypt connection</p>	<p>The parameter "Encryption Required" is enabled in the handset in combination with;</p> <p>1) Unencrypted base station(s); and/or,</p> <p>2) Unsupported base station(s).</p>	<p>1) Disable the "Encryption Required" parameter in handset; and/or,</p> <p>2) Enable the encryption in the base station(s); and/or,</p> <p>3) Use supported base station(s). Ask your supplier.</p>
<p>Not allowed</p>	<p>1) The user cannot login to the handset with the shared phone functionality enabled, due to another handset currently using the same extension (User).</p> <p>2) The user cannot logout from the handset with the shared phone functionality enabled, due to incorrect password (AC code).</p> <p>3) The extension (User) does not exist.</p> <p>4) The password is not correct.</p>	<p>1) Logout from the handset that uses the same extension.</p> <p>2) Enter #11*&lt;AC code&gt;# on the keypad and press the off-hook key to logout from the shared phone.</p> <p>3) Make sure that you entered correct extension. If needed, contact the system administrator.</p> <p>4) Make sure that you have entered correct password. Ask the system administrator if you have forgot the password.</p>

## 14 Operation Notice

### 14.1 Accessibility and Voice Quality



The base network is not always available. If you do not get in contact with your system, contact your system administrator. For best voice quality, avoid positioning near computer, radio or similar equipment.

#### Operating Area

The handset can only be used in the area covered by the system. Outside of this area the handset loses contact with the system. The signal strength icon is low and "Searching" is displayed.

#### Out of Range

When the handset leaves the system's coverage area a short beep sounds and the text "Searching" is displayed.

The out of range beep is repeated every minute for 30 minutes. The sound can be turned off by long pressing #  , or  .

When re-entering the coverage area it can take a couple of minutes before the handset is automatically registered with the system.

## 15 Maintenance

### 15.1 Maintenance of Batteries

#### 15.1.1 Battery Warnings





The "Low battery" icon is displayed when the battery has 10% or less remaining capacity left. In addition; a warning signal sounds every minute and the dialog window "Battery low. Charge now." appears.



The "Empty battery" icon is flashing when the battery has 5% or less remaining capacity left. In addition; a warning signal sounds every second and the dialog window "Battery empty. Shutting down." appears.

During a call, only the corresponding battery warning signal notifies the user. The warning signal cannot be silenced during a call. When not in call, the warning signal can be silenced by pressing # 8 or .

#### 15.1.2 Charge the Battery

Place the handset in the desktop charger or in the rack charger. An animated battery icon  is also shown in the display indicating charging by starting with its current charge and ending with the full charge. A filled battery icon  indicates a fully charged battery.

NOTE: Only use the prescribed chargers for charging.

#### 15.1.3 Charge Spare Batteries

Spare batteries can be charged with a separate battery pack charger. It can charge six batteries at the same time.

#### 15.1.4 Replace the Battery

If the standby time for the handset becomes too low, the battery should be replaced by a new one. Contact the system administrator or handset supplier for information about new batteries. Attach the battery as described in the illustration below. The battery is easy to replace. It is attached inside the battery lid and is connected to the handset in such a way that no misalignment of the contact is possible.

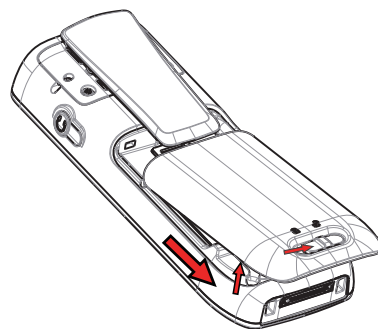

Figure 16. Easy replaceable battery, unlock the lid and remove the battery.

## 15.2 Easy Replacement of Handset

Easy replacement can be used if a handset needs to be replaced due to, for example, a broken display. The easy replacement procedure is done via the handset display and the DC4 Advanced Desktop Charger or the CR3 Charging Rack.

NOTE: Easy replacement is not supported when using DP1 Desktop Programmer.

The following settings are replaced during easy replacement:

- DECT registration
- User parameters (including User ID)
- Contacts
- The extension number is assigned to the new handset.

The following settings are not replaced during the easy replacement:

- Call list
- Messages
- Bluetooth pairing list
- Licenses.

### 15.2.1 Before Starting Easy Replacement Procedure

- 1 Check that both the old handset to be replaced and the new replacement handset are of the same device type.

NOTE: The Easy Replacement procedure can be used if the old and new handsets have different product licenses, that is, Talker, Messenger, and Protector. The new handset product license is not replaced by the old handset's product license during the procedure. However, a handset product license, can be moved to another handset using the WinPDM/Device Manager.

- 2 Use the WinPDM or the Device Manager to check that the software of DC4 Advanced Desktop Charger or CR3 Charging Rack is of version 1.3.x or greater. For more information on how to use the WinPDM/Device Manager, refer to the User Manual for the Device Manager or the Installation and Operational Manual for the Portable Device Manager (WinPDM), Windows version.
- 3 Make sure that the handset batteries are charged before starting the easy replacement procedure.
- 4 Switch off the new handset by long pressing .

### 15.2.2 Easy Replacement Procedure

During the Easy Replacement procedure, the LED indications on the charger can be used to follow the replacement procedure. For more details, see [LED Indications during Easy Replacement](#) on page 87.

**IMPORTANT:** Never remove a handset from the charger until the instructions in the display tells you to do so (see status on the LED on the charger if the display is broken). If there is an error indication it may be allowed to remove the handset, see [Figure 15. Update Completed while in Charger](#) on page 79 for further instructions.

After the old handset has been in the charger, the new handset needs to be placed in the charger regardless if the replacement was successful or not. Failing to do so may result in malfunction that requires the new handset to be returned for service.

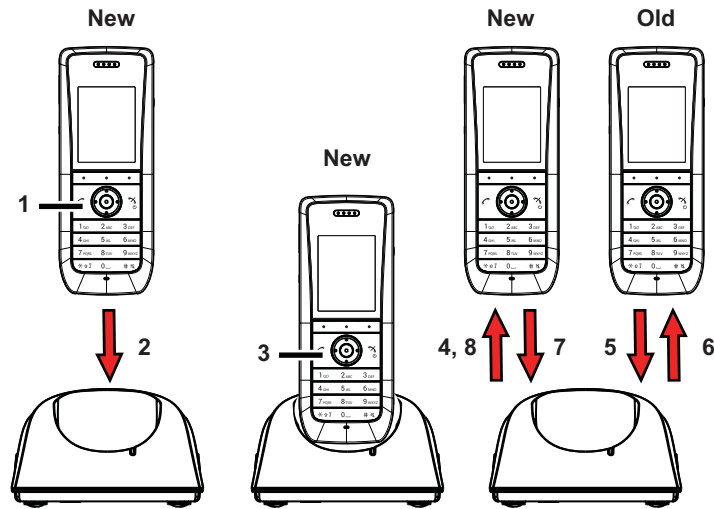





Figure 17. Easy Replacement via DC4 Advanced Desktop Charger.

- 1 On the new handset, press and hold 

Note: Do not release  until you are instructed to do so.
- 2 Put the new handset in the charger.
- 3 When the text "Start phone replacement?" is displayed, release  .  
Press "Yes" (left soft key).  
The text "Follow the instructions. Each step can take several minutes." appears in the display. Press "OK"(left soft key).
- 4, 5 When the text "Please insert old phone in charger" is displayed, replace the new handset with the old handset. The handset can either be switched on or off.

NOTE: The left charging slot in the CR3 Charging Rack has to be used for both handsets.

The handset is restarted and after a few seconds, the text "Saving settings. Do not remove phone from charger" appears. The charger LED changes to slow orange flashing. It may take several minutes.

**IMPORTANT:** If the old handset cannot communicate with the charger, put the new handset in the charger to restore its settings (that is, the handset's IPDI). If this step is not performed, the new handset must be sent for service. The old handset's settings might be transferred to the new handset by using WinPDM. refer to the Configuration Manual for the handset; see [17 Related Documents](#) on page 91.

- 6, 7 When the text "Please insert new phone in charger" is displayed, replace the old handset with the new handset. The text "Restoring settings" is displayed.

**IMPORTANT:** Do not remove the handset while the text "Restoring settings" is displayed.

- 8 When the text "Phone successfully replaced. Please remove phone to restart." appears in the display, remove the handset from the charger. The handset is automatically restarted.

### LED Indications during Easy Replacement

The following table shows the LED indications that are used for the charger during the easy replacement procedure.

LED indication	Description
Orange, flashing (1 000 ms on, 1 000 ms off)	File transfer during Easy Replacement.
Orange, flashing (100 ms on, 800 ms off)	"Change phone" indication during Easy Replacement.
Red, flashing (100 ms on, 800 ms off)	Error indication during Easy Replacement. Put back old handset in charger.
Red, flashing (900 ms on, 100 ms off)	Error during Easy Replacement. Service needed for both handsets.

See also [Figure 15. Update Completed while in Charger](#) on page 79.

### 15.3 Attach the Hinge-type Clip

Attach the hinge-type belt clip as described in the illustration below.

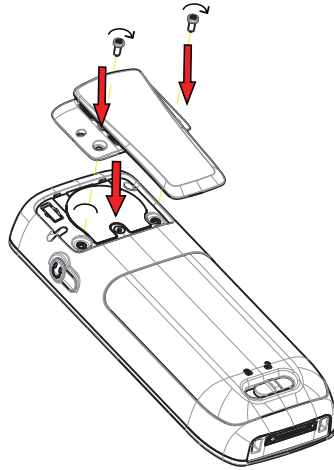

Figure 18. Screw the hinge-type clip into position.

### 15.4 Attach the Swivel-type Clip

Attach the swivel-type belt clip as described in the illustration below.

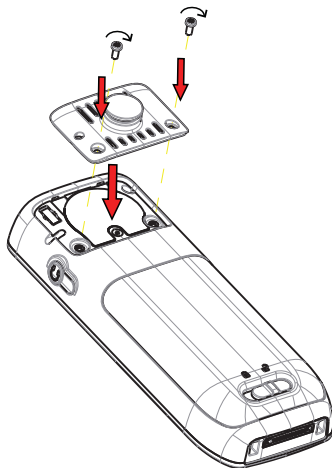

Figure 19. Screw the swivel-type clip into position.

### 15.5 Attach Cover for No Clip

Attach the enclosed cover as described in the illustration below when no clip is to be used



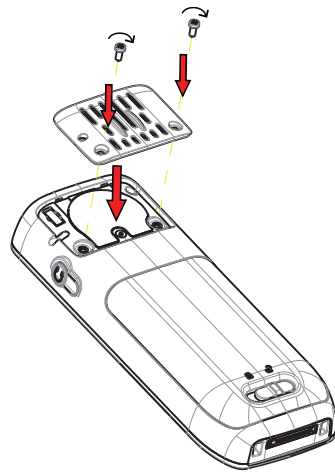

Figure 20. Screw the cover into position.

## 16. Energy Efficiency

Recommendations on how to save energy:

- Do not charge a battery when the ambient room temperature is above +40° C or below +5° C (above 104° F or below 41° F). Charging below +5° C will harm the battery and shorten the lifetime.
- Note that storing Li-Ion batteries at high temperature dramatically reduces its capacity. For example storage around +60° C reduces capacity with 20% in less than a month, permanently.
- Set the handset screen saver to the "Black also in call" option. The screen goes black and the backlight is turned off. In addition, the backlight is turned off when the handset is in call. This helps extend battery life especially when the user is on an extended call. See [Screen Saver](#) on page 71.
- The handset can be configured to switch off when placed in the charger. When removed from the charger the handset switches on automatically. See [8.1.5 In Charger Action when not in Call](#) on page 52.
- If the charger will not be used for a longer period of time, remove the power adapter to the charger.
- Do not put the handset in charger if no charging is needed.

## **17 Related Documents**

Configuration Manual, DH7 DECT Handset	TD 93190EN
Installation and Operational Manual Portable Device Manager (WinPDM), Windows version	TD 92712EN

## 18 Document History

Version	Date	Description
A	1 Dec 2016	First released version.

## Appendix A. Bluetooth Headset

### A.1 Introduction

Bluetooth technology replaces the cord between the handset and the headset. This allows the user to move more freely and eliminates the risk of a headset cord getting stuck.

Bluetooth supported functions:

- Pair the handset with it's headset
- Choose which device to use when making a call
- Play ring signal in the Bluetooth Headset
- Answer and connect sound to the Bluetooth Headset when answering with the headset's button.
- End call with the Bluetooth headset's button
- Transfer audio to/from Bluetooth headset during call, using the menu in the handset.
- Increase/decrease the volume in the Bluetooth headset with the volume buttons on the handset.

### A.2 Icon

See [2.3 Icons and Text in the Display](#) on page 7.

### A.3 Wear

For optimal performance wear the Bluetooth headset and the handset on the same side of your body. The best audio quality in the headset is achieved when no obstructions, including your body, are between the headset and the handset.

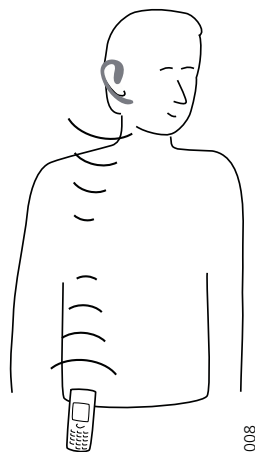

Figure 21. Wear the headset and the handset on the same side of your body.

### A.4 Headsets

A number of Bluetooth headsets for different work situations have been tested together with the handset. Refer to the datasheet for a list of verified Bluetooth headsets.

Since the Bluetooth supports the Bluetooth standard, other headsets may also work although not verified.

**Note:** The Bluetooth headset may have more or less functions than described here, refer to the Manual for the Bluetooth headset.

## A.5 Operation

Step between the menus with the navigation key . Confirm each menu selection by pressing the Soft key "Select".

### A.5.1 Enable Bluetooth

To enable the Bluetooth function enter  in the handset menu, select Bluetooth and select "Enable".

### A.5.2 Pair and Connect a Bluetooth Headset

Before a headset can be used a connection (pairing) between the headset and the handset must be established.

- 1 Place the Bluetooth headset and the handset next to each other.
- 2 Enable Bluetooth, see [A.5.1 Enable Bluetooth](#).
- 3 Put the Bluetooth headset in pairing mode, refer to the user manual for the Bluetooth headset.
- 4 On the handset enter  in the menu, select "Bluetooth" > "Headset", "Add new". A dialog "Put headset in Pairing mode" is displayed.
- 5 Press "OK". It now searches for a Bluetooth headset to connect to.
- 6 When headset is found, press "Pair".
- 7 If needed, enter PIN code, see user manual for the Bluetooth headset. Press "OK".

The dialog *Successful pairing* appears if the pairing process was successful. The Bluetooth headset is also connected and this is indicated by a colored square  in front of the headset.

### A.5.3 Add another Bluetooth Headset

Up to eight headsets can be paired to the handset, but only one at a time can be selected. To pair another headset repeat section "Pair and Connect a headset" steps 1-6.

The paired headsets are displayed by a default name in the handset menu "Headset". See [A.5.6 Change the name of Bluetooth headset](#)

### A.5.4 Select a Bluetooth Headset

To activate a Bluetooth headset, do as follows:

- 1 Enter  in the handset menu and select "Bluetooth" > "Headset".
- 2 Select a headset by pressing up or down on the navigation key.
- 3 Press the soft key "Select". "Connection successful" is displayed. The headset is now selected.

When a new headset has been selected any previous headset is disconnected automatically.

### A.5.5 Remove a Headset

To remove a Bluetooth headset, do as follows:

- 1 Enter  in the handset menu and select "Bluetooth" > "Headset".
- 2 Select a headset by pressing up or down on the navigation key.
- 3 Press the soft key "More".
- 4 Select "Delete" and confirm with the soft key "Yes".

### A.5.6 Change the name of Bluetooth headset

The name, in the headset list, of the headset is the default name for the headset.

To change the name, do as follows:

- 1 Enter  in the handset menu and select "Bluetooth" > "Headset".
- 2 Select a headset by pressing up or down on the navigation key.
- 3 Press the soft key "More".
- 4 Select "Edit name". Enter a name, see [2.5 Alphanumeric Keys](#) on page 13.

## A.6 Calling

### A.6.1 Make a Call

Dial the number on the handset and press the soft key "Call", or the Off-hook key. When "Transfer call to phone?" is displayed press "No" or ignore the message to use the Bluetooth Headset. Press "Yes" to use the handset.

### A.6.2 Answer a Call

A ring signal sounds in both the selected Bluetooth headset and the handset to signal an incoming call.

To answer the call in the Bluetooth headset, press the button on the headset.

To answer the call in the handset press the Off-hook key on the handset.

### A.6.3 End a Call

To end the call press the button on the headset or the On-hook key on the handset.

## A.7 Volume and Mute Control

### A.7.1 Adjust the Volume During a Call

Depending on the Bluetooth headset it might be possible to adjust the volume on the headset\*. On the handset press the upper Volume button on the upper left side to increase the volume and the lower Volume button to decrease the volume in the headset.

### A.7.2 Turn the Microphone On/Off During a Call

Mute the headset and the handset with the Sound off key on the handset. See [5.4.4 Turn the Microphone On or Off during a Call](#) on page 28.

## **A.8 Messaging**

When a text message is received during an ongoing call, a beep sounds in the Bluetooth headset.

## **A.9 Transfer a call**

### **A.9.1 Transfer a Call to the handset**

To transfer a call to the handset from the Bluetooth headset, press the soft key "More" on the handset during the call, and select "Audio transfer".

### **A.9.2 Transfer a Call to the Bluetooth Headset**

To transfer the call to the Bluetooth headset, press the soft key "More" on the handset during the call, and select "Audio transfer".

A call can also be transferred to the Bluetooth headset by pressing the button<sup>1</sup> on the Bluetooth headset.

## **A.10 Switch to a Headset with Cord**

If a headset with a cord is connected during a call, the call is transferred to this headset automatically.

## **A.11 Menu Tree**

See [3.8 Settings](#) on page 20.

## **A.12 Operation Notice**

### **A.12.1 Accessibility and Voice quality**

Bluetooth uses the frequency of 2.45 GHz. WLAN, microwave oven, and other devices that use the same frequency can disturb the use of a Bluetooth headset.

### **A.12.2 Operation Area**

Maximum distance between the headset and the handset is 10 metres. The communication distance between the handset and headset may vary considerably due to the environment and disturbances from other 2.45 GHz equipment. Different headsets can also give different communication distances.

### **A.12.3 Out of Range**

If a connection cannot be made with the selected Bluetooth headset the call is transferred automatically to the handset.

If the Bluetooth headset and the handset get out of range from each other the connection is temporarily lost. Since the last connected headset is always considered "selected", the connection is automatically established again when a call is made or received.



## **A.13 Environmental Requirements**

### **A.13.1 Bluetooth Headset Battery**

refer to the manual for the Bluetooth headset.

## A.14 Troubleshooting

Problem	Reason	Solution
No headset found	Headset is turned off	Turn on headset <sup>1</sup>
	Headset is out of battery	Charge headset <sup>1</sup>
	Headset is out of range	Move headset closer to handset < 10 metre.
	Headset is not in pairing mode	Turn headset into pairing mode <sup>1</sup>
Pairing fails	Headset is not in pairing mode	Turn headset into pairing/discoverable mode <sup>1</sup>
	Incorrect PIN entered	Try again and enter correct PIN <sup>1</sup>
Connecting fails/Failed to connect headset	Headset is not turned on	Turn on headset <sup>1</sup>
	Headset is out of range	Move headset closer to handset
	Link key in headset has been deleted	Repeat pairing procedure <sup>1</sup>
	Headset is already connected to another headset	Disconnect headset from the other headset
	Too close to disturbing devices.	Disturbing devices can be WLAN equipment, microwave etc.
Headset can not connect to handset (see headset manual for details on how to connect)	Headset is not turned on	Turn on handset <sup>1</sup>
	Headset is out of range	Move handset closer to headset
	Bluetooth module is disabled	Enable Bluetooth in Bluetooth menu
	Another headset is already connected to the handset	Disconnect the connected headset
	Link key is missing in either headset or handset.	Repeat pairing procedure <sup>1</sup>
	Too close to disturbing devices.	Disturbing devices can be WLAN equipment, microwave etc.

1. Refer to the Manual for the Bluetooth headset

## Appendix B. Safety Precautions

Read this chapter before using the handset.

NOTE: Product Designator for regulatory purposes of the DECT Handset is DH7.

### Safe operation

For safe and efficient operation of the handset, observe the guidelines given in this manual and all necessary safety precautions when using the handset. Follow the operating instructions and adhere to all warnings and safety precautions located on the product, the Regulatory Information delivered with the handset, and this User Manual.

Do not disassemble the handset. Disassembling the handset voids the warranty. The handset consists of no consumer serviceable components. Service should be performed by an Authorized Service Center only.

Changes or modifications to the equipment not expressly approved by the party responsible for compliance could void the user's authority to operate the equipment. Frequency Range

The handset is a radio transmitter and receiver. When it is on, it receives and sends out radio frequency (RF) energy. The handset operates on different frequency ranges depending on market and employs commonly used modulation techniques:

EU (ETSI): 1880-1900 MHz/250mW  
USA/Canada (FCC): 1920-1930 MHz/100mW

### B.1 Regulatory Information (EU and EFTA)

#### B.1.1 Exposure to Radio Frequency Signals

	Close to ear	Handheld/body mounted
DH7-xxxx	0.075 W/kg (10 g)	0.076 W/kg (10 g)

THIS MOBILE DEVICE MEETS GUIDELINES FOR EXPOSURE TO RADIO WAVES. Your mobile device is a radio transmitter and receiver. It is designed not to exceed the limits for exposure to radio waves recommended by international guidelines. These guidelines were developed by the independent scientific organization ICNIRP and include safety margins designed to assure the protection of all persons, regardless of age and health.

The exposure guidelines for mobile devices employ a unit of measurement known as the Specific Absorption Rate or SAR. The SAR limit stated in the ICNIRP guidelines is 2.0 W/kg averaged over 10 grams of tissue. Tests for SAR are conducted using standard operating positions with the device transmitting at its highest certified power level in all tested frequency bands. The actual SAR level of an operating device can be below the maximum value because the device is designed to use only the power required to reach the network. That amount changes depending on a number of factors such as how close you are to a network base station. The highest SAR value under the ICNIRP guidelines for use of the device at the ear is 0.201 W/kg and at the body is 0.278 W/kg (The measure distance of 1.5 cm). Use of device accessories and enhancements may result in different SAR values. SAR values may vary depending on national reporting and testing requirements and the network band.

## B.2 Regulatory Compliance Statements (USA and Canada only)

FCC ID: DH7-xBxx:BXZDH7BT DH7-xDxx:BXZDH7BT DH7-xAxx:BXZDH7
IC: DH7-xBxx:3724B-DH7BT DH7-xDxx:3724B-DH7BT DH7-xAxx:3724B-DH7

### B.2.1 FCC and IC Compliance Statements

This equipment has been tested and found to comply with the limits for a Class B digital device, pursuant to part 15 of the FCC Rules. These limits are designed to provide reasonable protection against harmful interference in a residential installation. This equipment generates, uses and can radiate radio frequency energy and, if not installed and used in accordance with the instructions, may cause harmful interference to radio communications. However, there is no guarantee that interference will not occur in a particular installation. If this equipment does cause harmful interference to radio or television reception, which can be determined by turning the equipment off and on, the user is encouraged to try to correct the interference by one or more of the following measures:

- Reorient or relocate the receiving antennas.
- Increase the separation between the equipment and receiver.
- Connect the equipment into an outlet on a circuit different from that to which the receiver is connected.
- Consult the dealer or an experienced radio/TV technician for help.

Privacy of communications may not be ensured when using this handset.

### B.2.2 Exposure to Radio Frequency Signals

This equipment complies with FCC radiation exposure limits set forth for an uncontrolled environment. This device complies with FCC SAR limit of 1.6 W/kg. The maximum SAR value measured, see below.

	Head	Body
DH7-xxxx	0.042 W/kg	0.074 W/kg

The handset is designed to be worn with the display towards the body for best radio performance. SAR testing is made with no separation, to approve the device to be carried close to the body.

This device must not be co-located or operating in conjunction with any other antenna or transmitter.

Use of non-approved accessories may violate the FCC and IC guidelines for RF exposure and should be avoided.

## B.3 Precautions

### B.3.1 Handset

- Avoid volume levels that may be harmful to your hearing. Exposure to excessive sound pressure from a handset's earpiece or headset may cause permanent hearing loss.

- Low volume levels might result in missed alerts.
- Only use the handset in temperatures between: -5 °C and +45 °C (23 °F and 113 °F).
- Avoid exposing the handset to direct sunlight, heat sources and moisture.
- Do not place a cold handset in a charger.
- Avoid sudden temperature changes to prevent condensation in the handset. It is recommended to put the handset into an air tight plastic bag until the temperature is adjusted, for example, when entering or leaving a cold/heated building on a warm/cold day.
- If the handset has been exposed to water or condense, remove the battery immediately, and let it dry completely before re-inserting the battery.
- Do not expose the handset to open flame.
- Protect your handset from aggressive liquids and vapors.
- Remove the handset from the Charger before cleaning the handset to reduce risk of electric shock.
- Keep the handset away from strong electromagnetic fields.
- The handset may retain small metal objects around the earpiece region.
- Do not place heavy objects on the handset.
- Do not allow children to play with the product packaging material. This could cause choking and/or suffocation.
- Do not allow children to play with the handset. It is not a toy.

### **B.3.2 Battery**

- Do not immerse the battery into water. This could short-circuit and damage the battery.
- Do not expose the battery to an open flame. This could cause the battery to explode.
- Do not allow the metal contacts on the battery to touch another metal object. This could short-circuit and damage the battery.
- Do not leave the battery where it could be subjected to extremely high temperatures, such as inside a car on a hot day.
- Use the Desktop Charger, the Charging Rack, or the Battery Pack Charger for charging. Charge the battery for at least one hour the first time you use the battery.
- Do not charge the battery when the ambient room temperature is above 40 °C or below 5 °C (above 104 °F or below 41 °F).
- Do not attempt to take the battery apart.
- Do not remove the battery, unless it needs to be replaced.
- Power off the handset before removing the battery.

#### **Battery Disposal**

Defective batteries must be returned to a collection point for chemical waste disposal.